

La maniera moderna

La Roma di Giulio II e Leone X

La profdiArte

IMPARA L'ARTE



Bramante

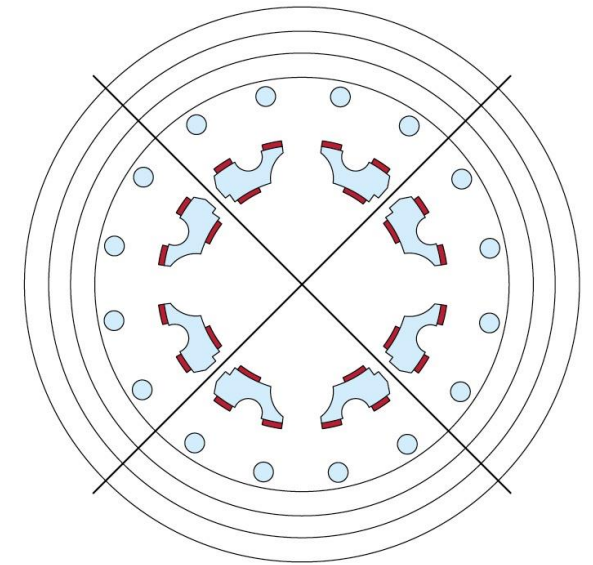
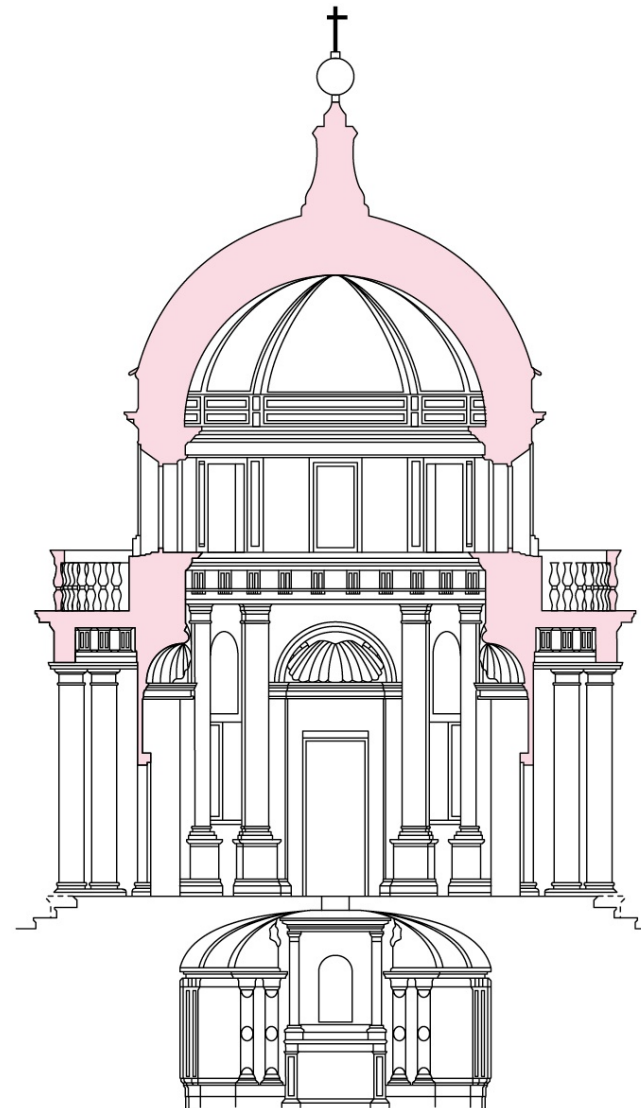

Tempietto di San Pietro in Montorio (1502-08). Sorto sul luogo dove la tradizione vuole che sia stato crocifisso l'apostolo Pietro, è circondato da una peristasi di sedici colonne doriche sovrastate da un fregio con metope e triglifi.

La Roma di Giulio II e Leone X



Bramante



La Roma di Giulio II e Leone X



Bramante

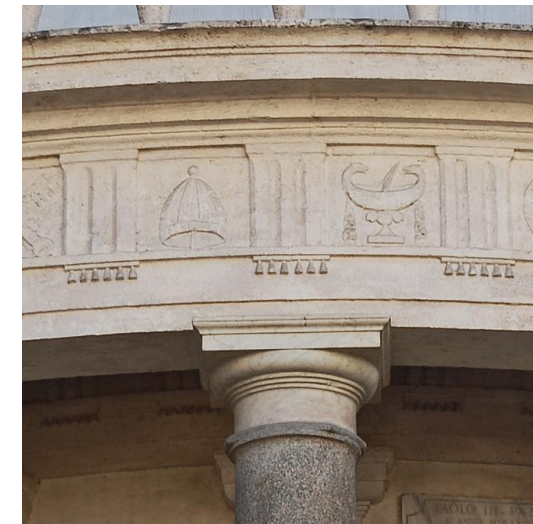

La Roma di Giulio II e Leone X

Bramante





Storia della Basilica di San Pietro

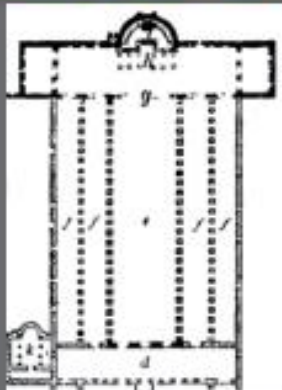

San Pietro paleocristiana
Voluta dall'imperatore Costantino, presenta pianta longitudinale a croce latina

333

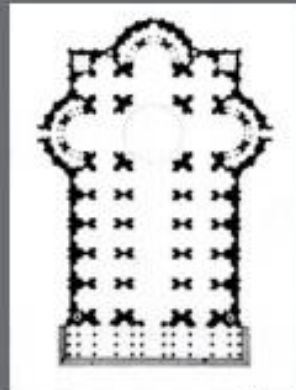

Raffaello

Su richiesta della Chiesa Romana disegnò una pianta a croce latina e absidi sporgenti

1516

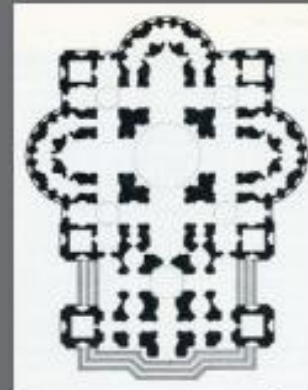

Antonio da Sangallo

La sua chiesa a pianta centrale si estende con una breve navata per sembrare una croce latina

1538

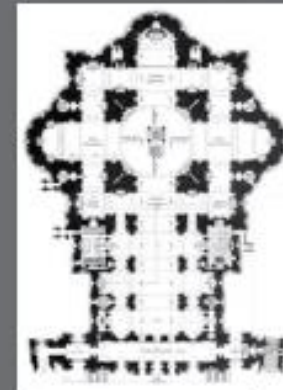

Carlo Maderno

Realizzò un'estensione del disegno di Michelangelo tale che la cupola non fu più visibile

1607



1500

1600

Donato Bramante

La nuova pianta rinascimentale è basata su una croce greca con una cupola centrale

1505

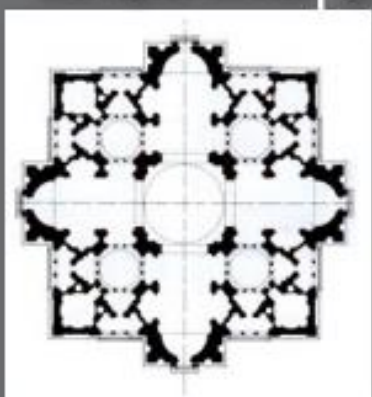

Baldassarre Peruzzi

La sua pianta è simile a quella di Raffaello ma la forma è di nuovo a croce greca

1520

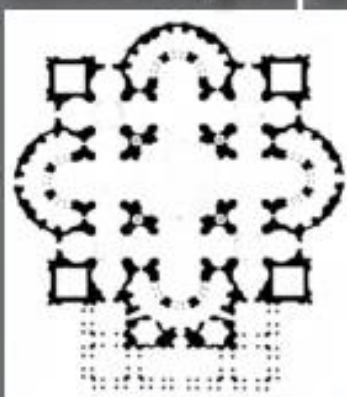

Michelangelo

Ripartì dall'idea di pianta centrale di Bramante con una struttura più articolata

1546



Bramante

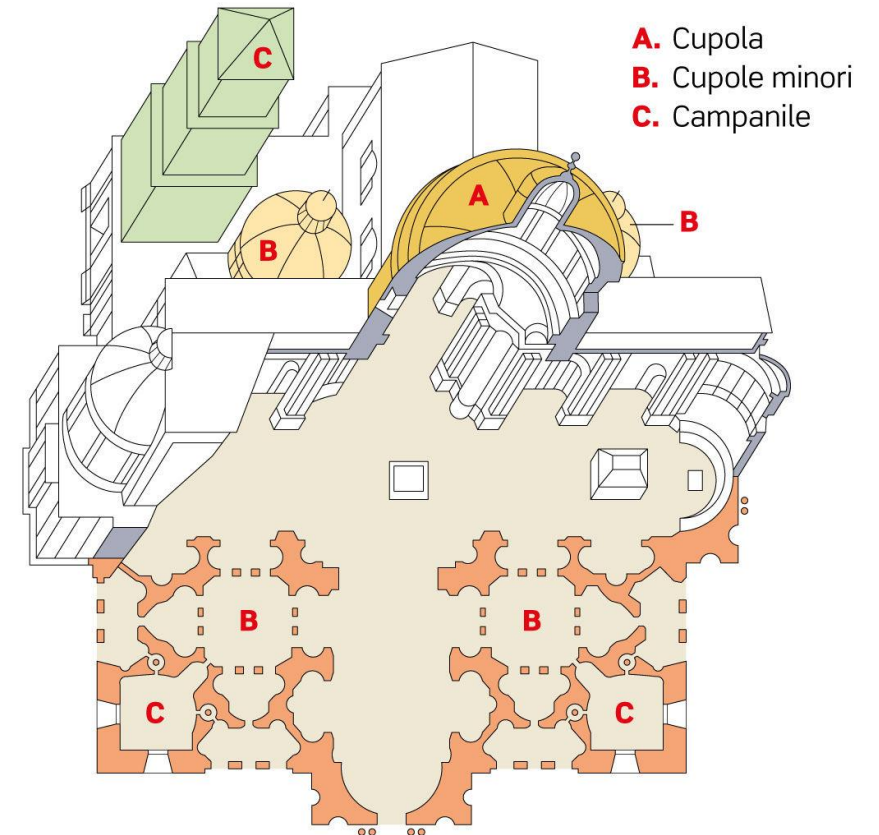
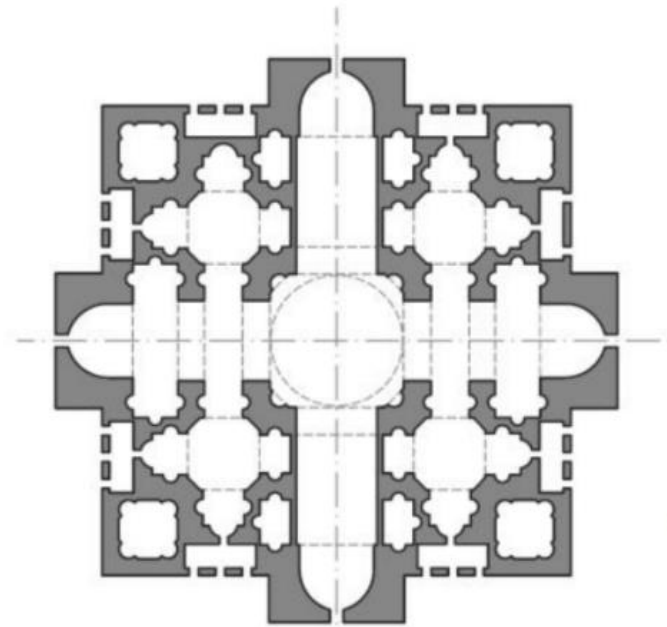
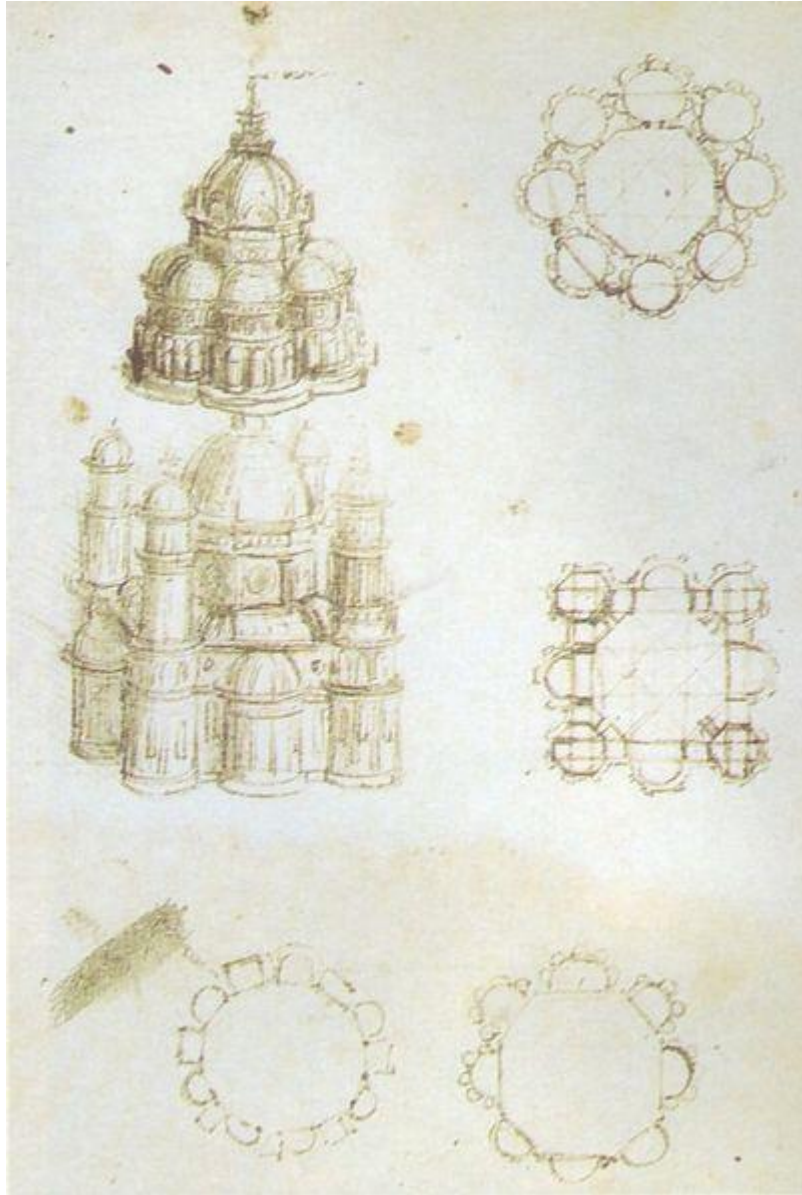

La Roma di Giulio II e Leone X

Raffaello

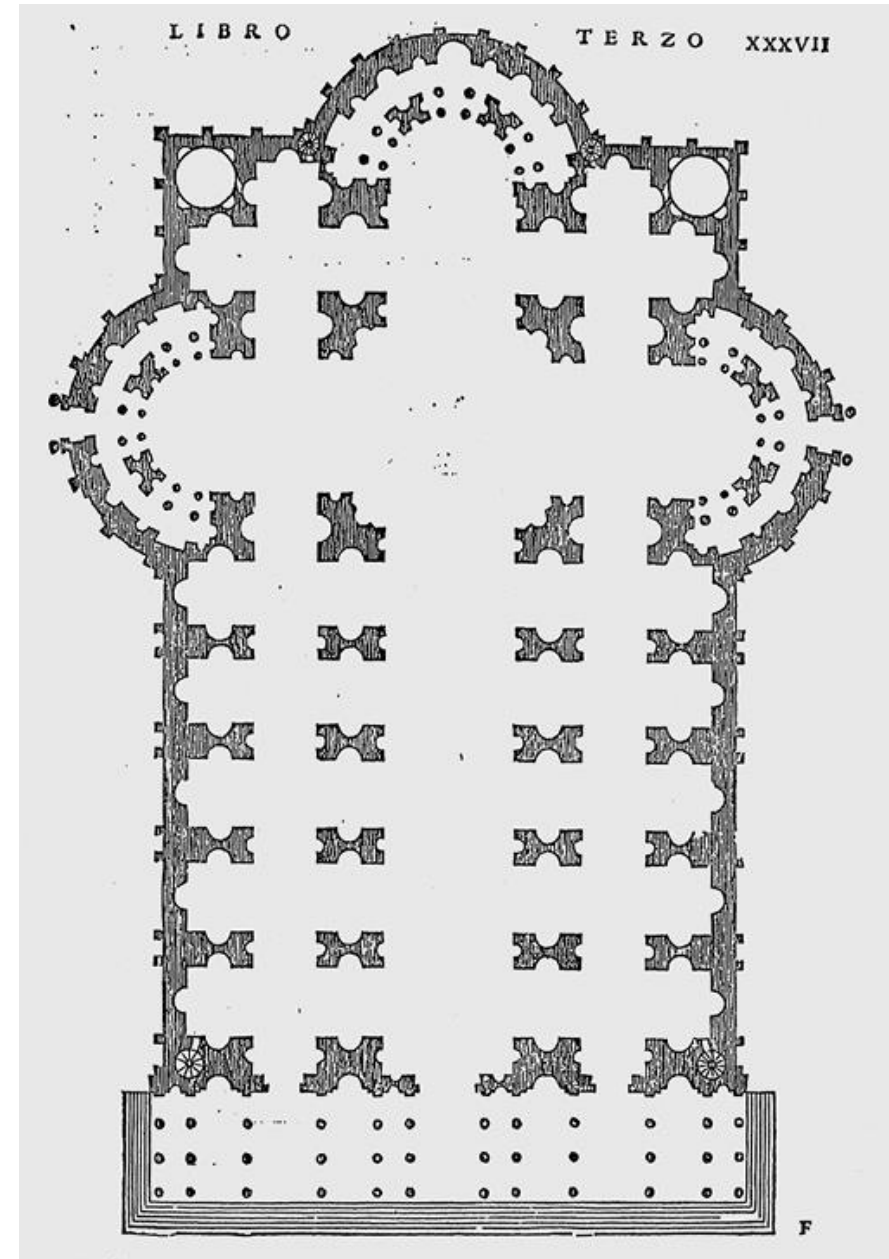
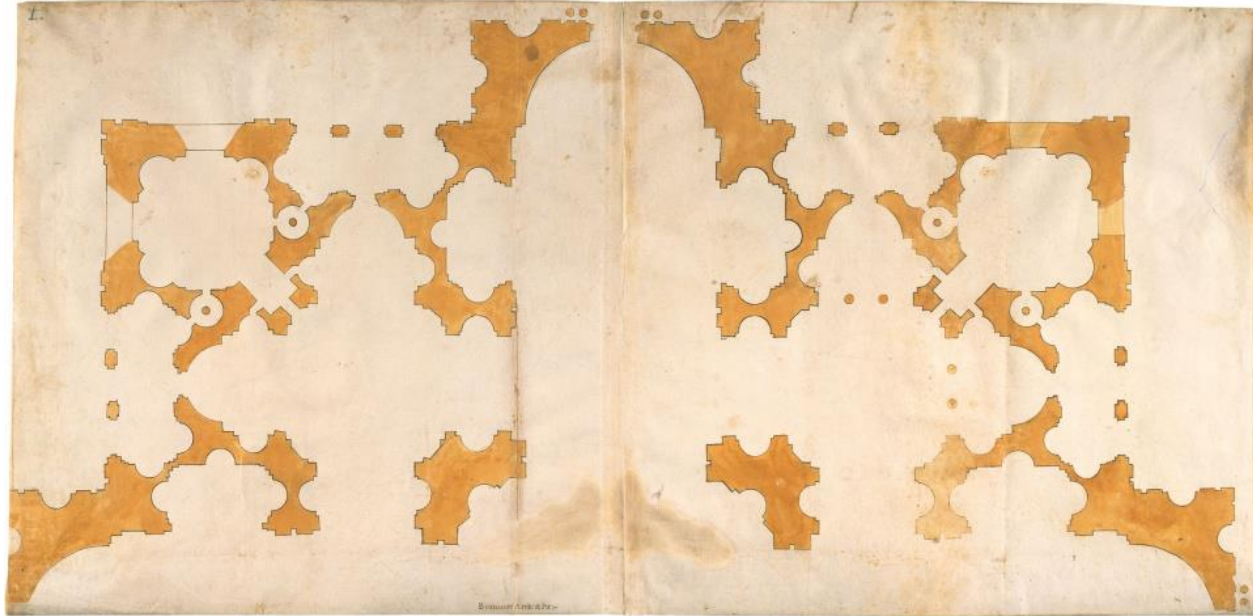

La Roma di Giulio II e Leone X



Bramante

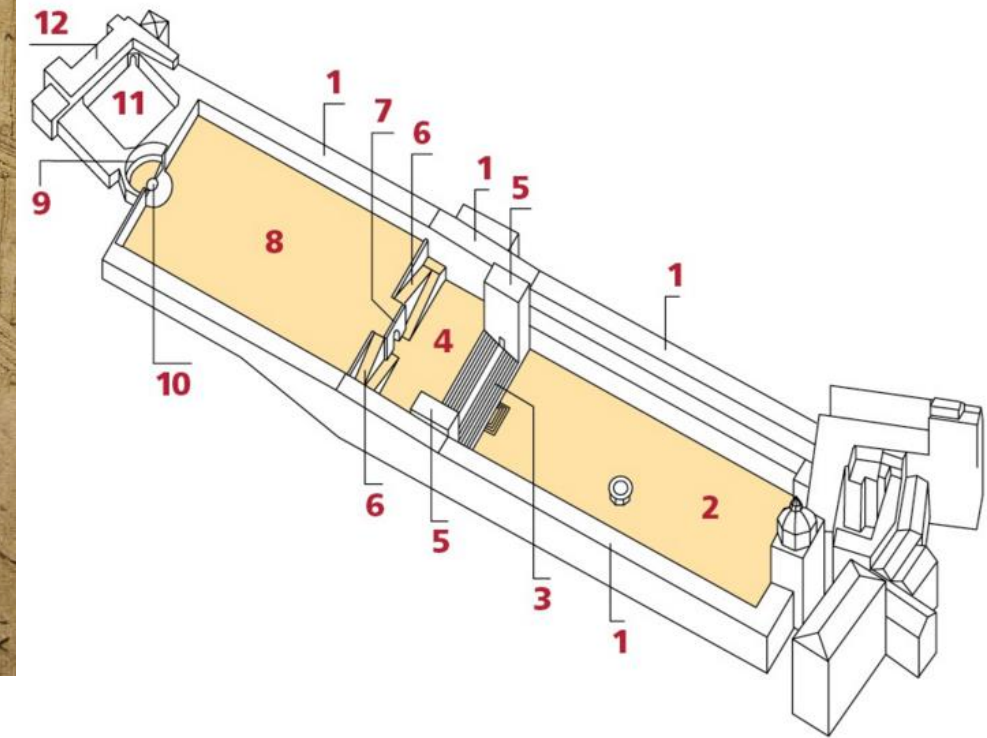
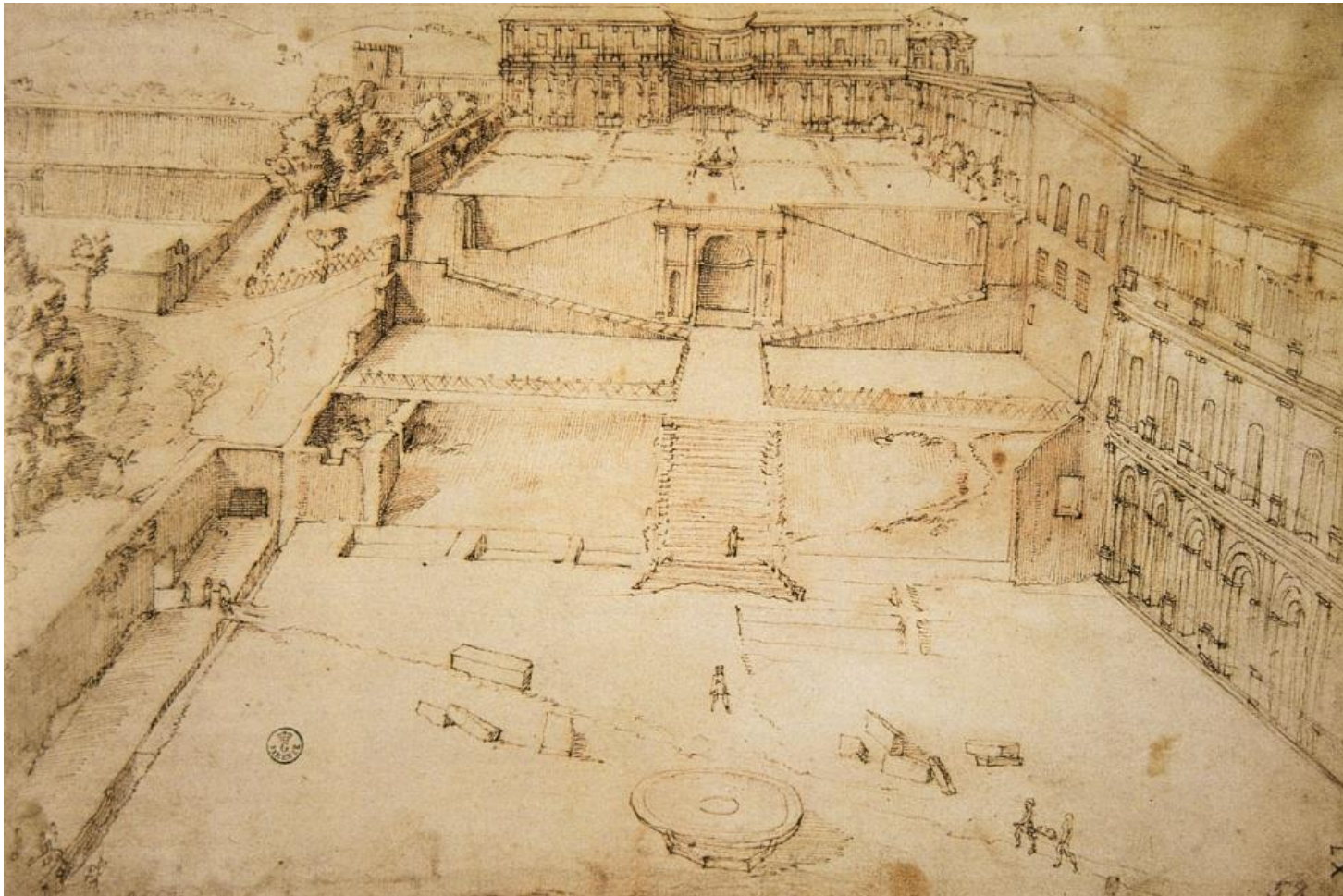

17.43
Schema del Belvedere Vaticano. Ricostruzione
assonometrica (da J.A. Ackerman).

- 1. Loggiato
- 2. Primo cortile
- 3. Gradinata

- 4. Giardino
- 5. Torre
- 6. Scala a doppia rampa
- 7. Ninfeo
- 8. Cortile della Pigna

- 9. Esedra
- 10. Scala concavo-convessa
- 11. Cortile ottagonale
- 12. Villa di Innocenzo VIII

La Roma di Giulio II e Leone X

Bramante



La Roma di Giulio II e Leone X

Raffaello – Le stanze Vaticane

Stanza di Costantino

- 14. Donazione di Costantino
- 15. Apparizione della Croce a Costantino
- 16. La battaglia di ponte Milvio
- 17. Battesimo di Costantino

Stanza dell'incendio di Borgo

- 10. Giuramento di Leone III
- 11. Battaglia di Ostia
- 12. Incendio di Borgo
- 13. Incoronazione di Carlo Magno

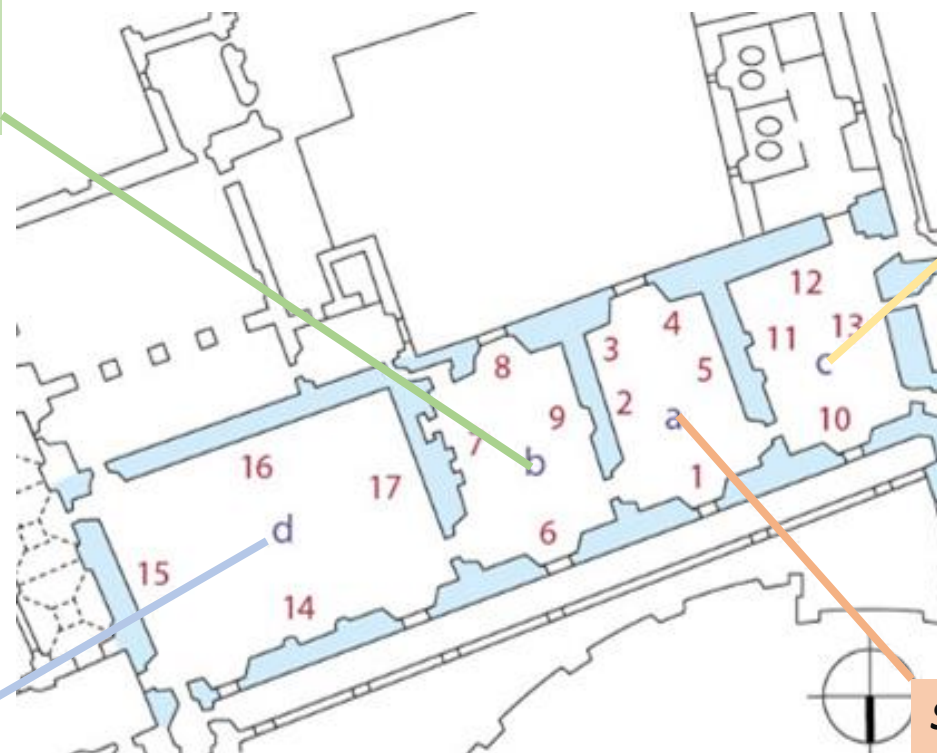

Stanza di Eliodoro

- 6. Liberazione di San Pietro dal carcere
- 7. Cacciata di Eliodoro dal tempio
- 8. Messa di Bolsena
- 9. Incontro di Leone Magno e Attila

Stanza della Segnatura

- 1. Il Parnaso
- 2. La scuola di Atene
- 3. La consegna delle Pandette a Giustiniano
- 4. Gregorio IX approva le Decretali
- 5. La disputa del Sacramento

La Roma di Giulio II e Leone X

Raffaello – Le stanze Vaticane



Stanza della Segnatura

1. Il Parnaso
2. La scuola di Atene
3. La consegna delle Pandette a Giustiniano
4. Gregorio IX approva le Decretali
5. La disputa del Sacramento



La Roma di Giulio II e Leone X

Raffaello – Le stanze Vaticane



La Roma di Giulio II e Leone X

Raffaello – Le stanze Vaticane



La Roma di Giulio II e Leone X



Raffaello – Le stanze Vaticane

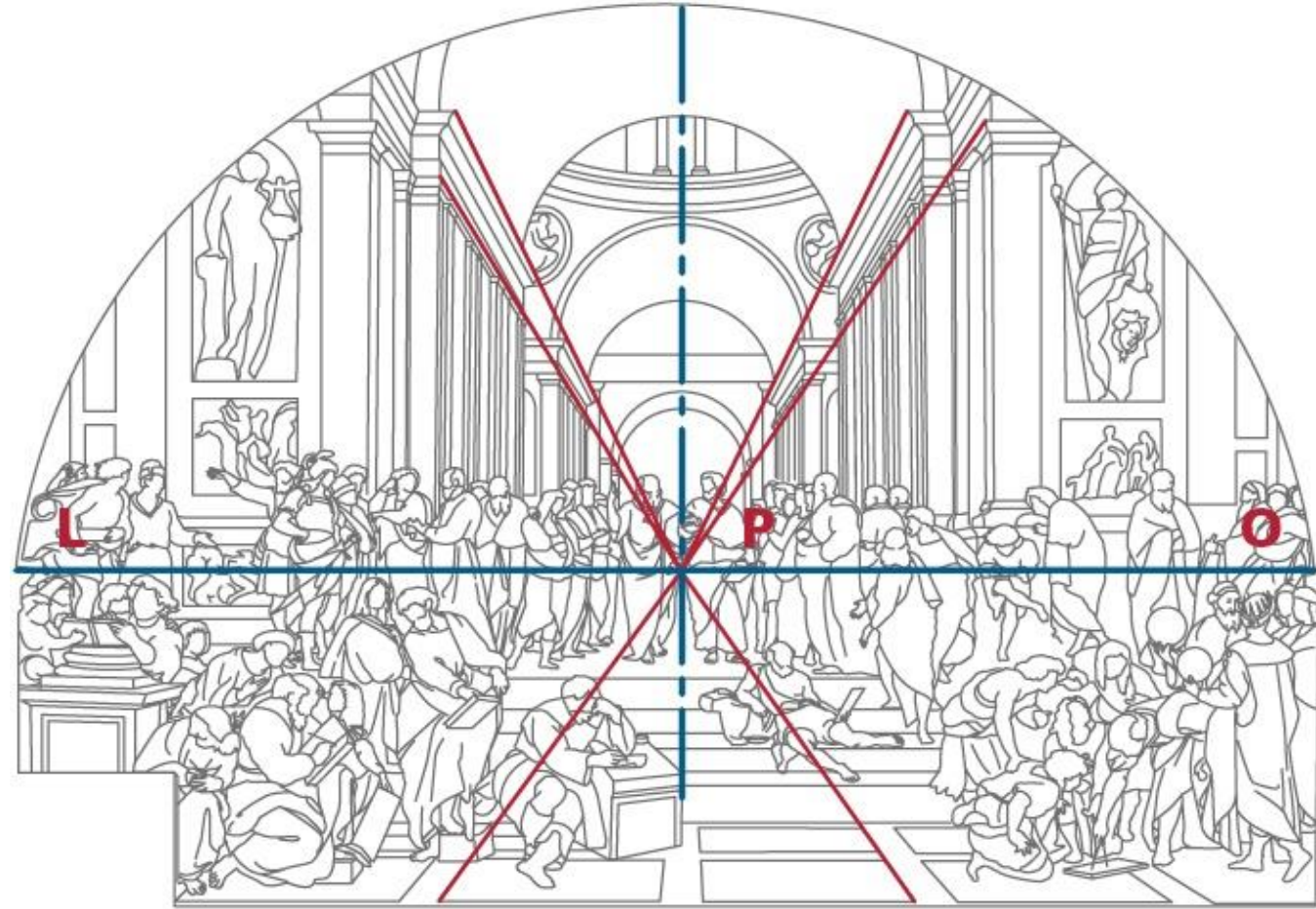

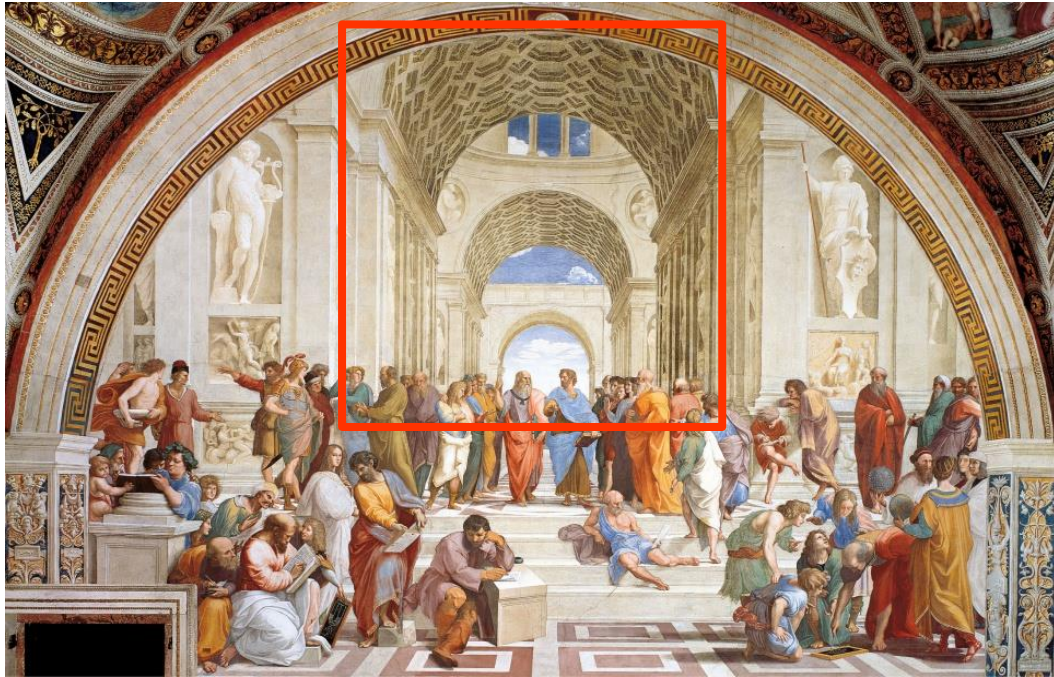

Architettura

- Raffaello immagina il «tempio della filosofia»
- Struttura architettonica grandiosa impostata secondo la tradizione prospettica fiorentina;
- Si ispira alla nuova basilica di San Pietro progettata da Bramante e alla rivisitazione degli edifici classici come la Basilica di Massenzio



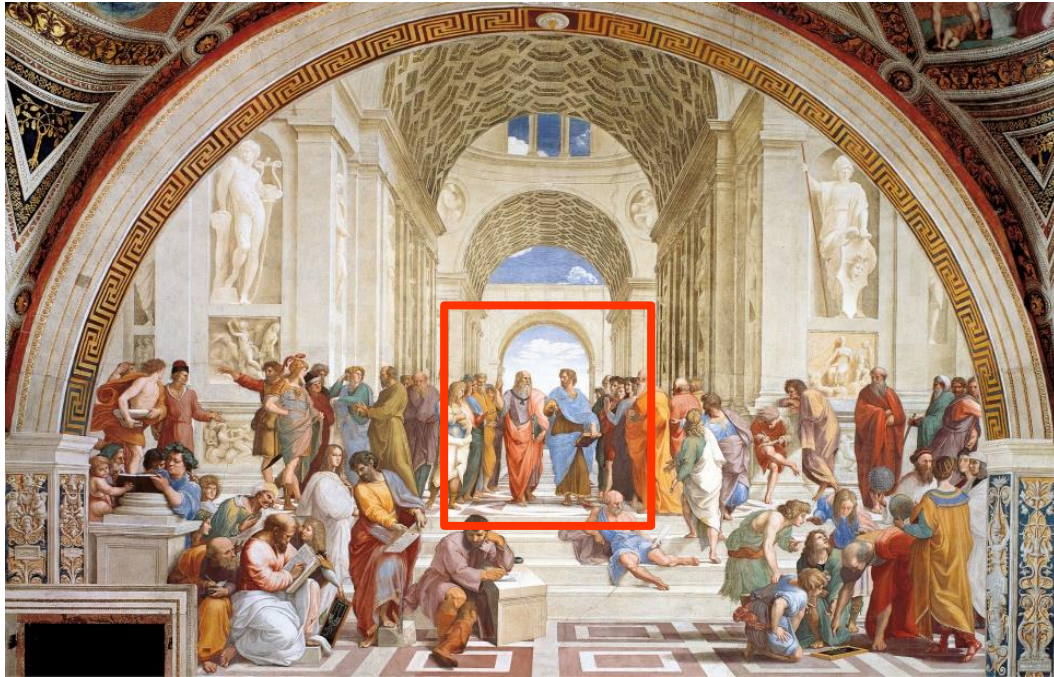

Aristotele e Platone

- Platone con il Timeo, guarda al mondo delle idee, insegna la sapienza, indica il cielo;
- Aristotele, con l'etica insegna la scienza e punta alle cose terrene.
- Platone ha le sembianze di Leonardo da Vinci



La Roma di Giulio II e Leone X

Raffaello – Le stanze Vaticane



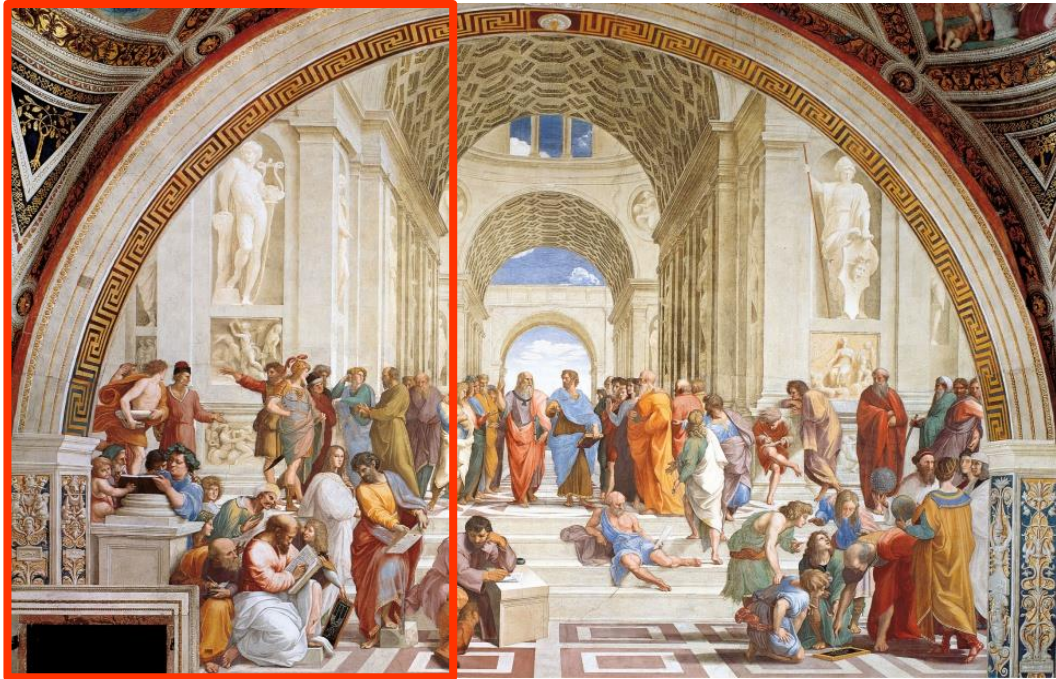

La metà sinistra

- Cinque gruppi di personaggi quasi tutti in atteggiamenti dinamici e dialoganti;
- In cima alla gradinata al centro i Socratici;
- Accanto a loro sulla sinistra i Sofisti;
- In primo piano gli epicureisti;
- I Pitagorici
- Eraclito



La Roma di Giulio II e Leone X



Raffaello – Le stanze Vaticane

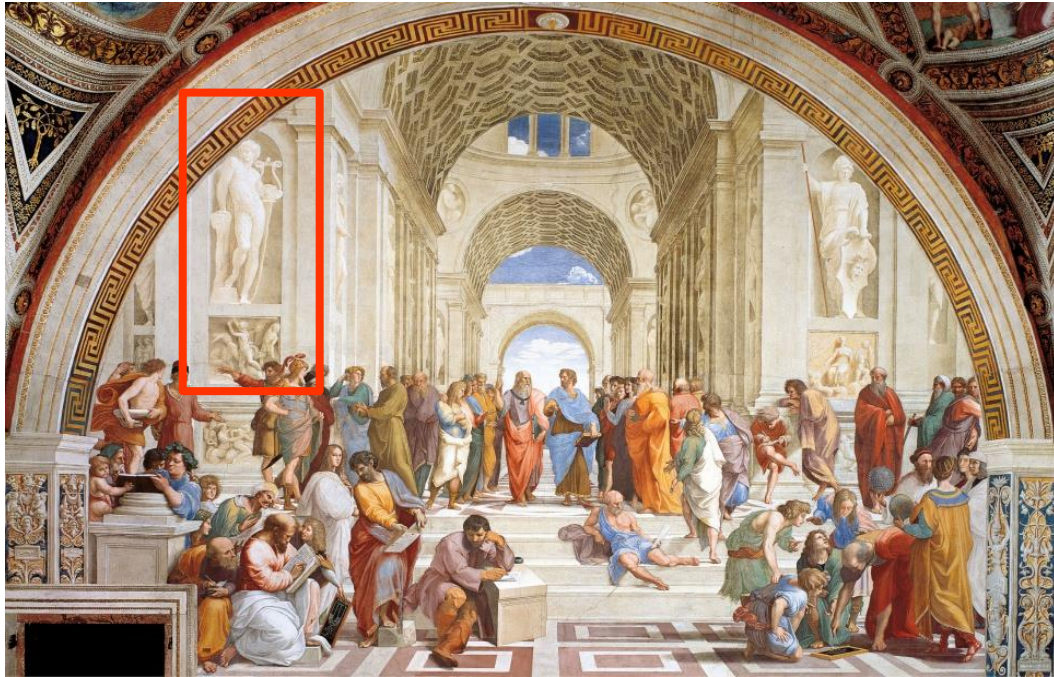

Apollo

Signore del Sole, dell'Armonia della Poesia e della Musica



La Roma di Giulio II e Leone X

Raffaello – Le stanze Vaticane

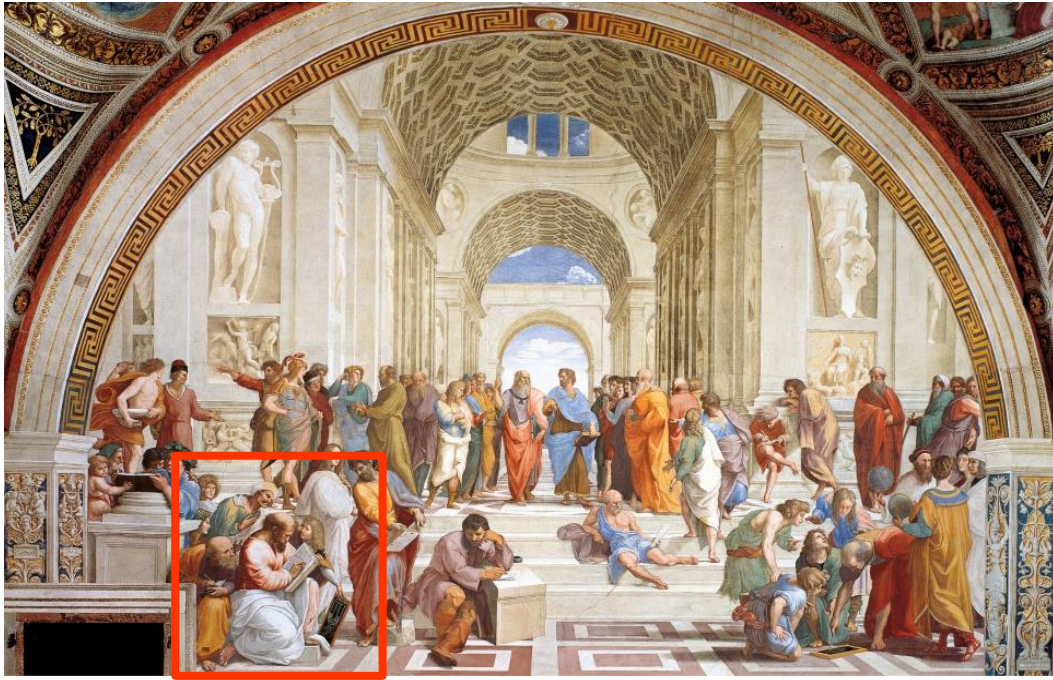

Pitagora

- Matematico, filosofo, astronomo;
- Un allievo gli mostra una lavagna. Su di essa non è rappresentato il teorema bensì una lira stilizzata a quattro corde nelle quali vengono indicati i rapporti numerici che stanno alla base dei suoni. Furono i pitagorici a rilevare che molti fenomeni della natura erano riconducibili a rapporti matematici (compresa la musica).
- Alle spalle un anziano (Anassimandro) e un uomo con il turbante (Averroè)





Empedocle e il misterioso giovane

- Filosofo che nel suo poema indicava con forza l'efficacia delle dottrine pitagoriche;
- Il giovane uomo viene identificato come Francesco Maria della Rovere (l'uomo che avrebbe favorito Raffaello alle stanze vaticane)



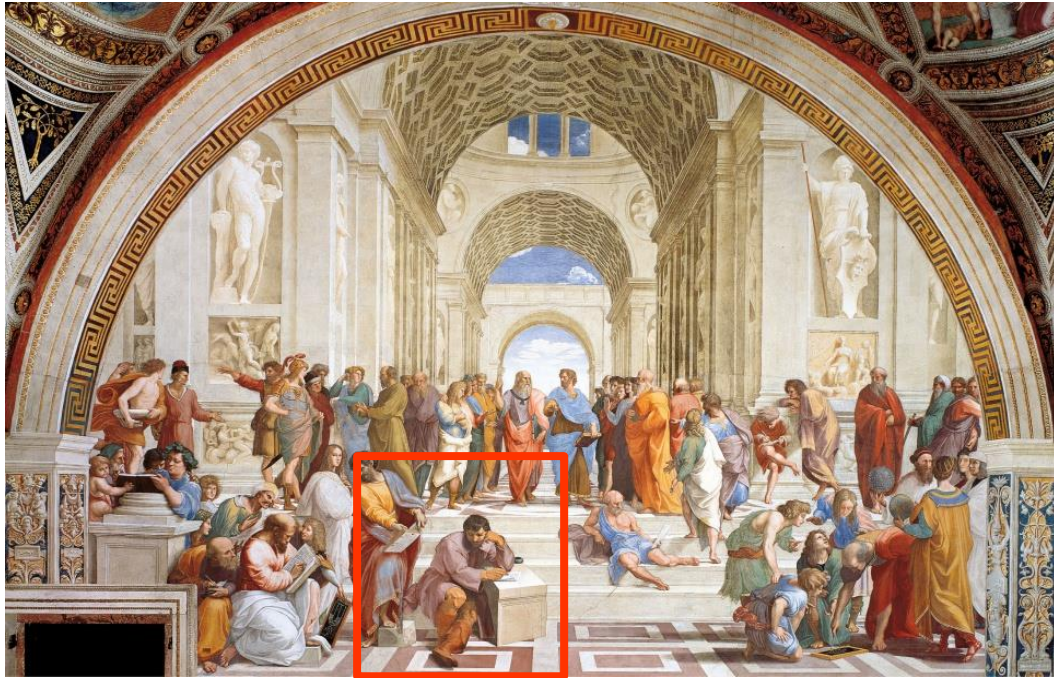

Heraclito

- Figura, per tradizione solitaria e pensierosa, propensa al distacco dalle cose del mondo
- Ritratto il volto di Michelangelo

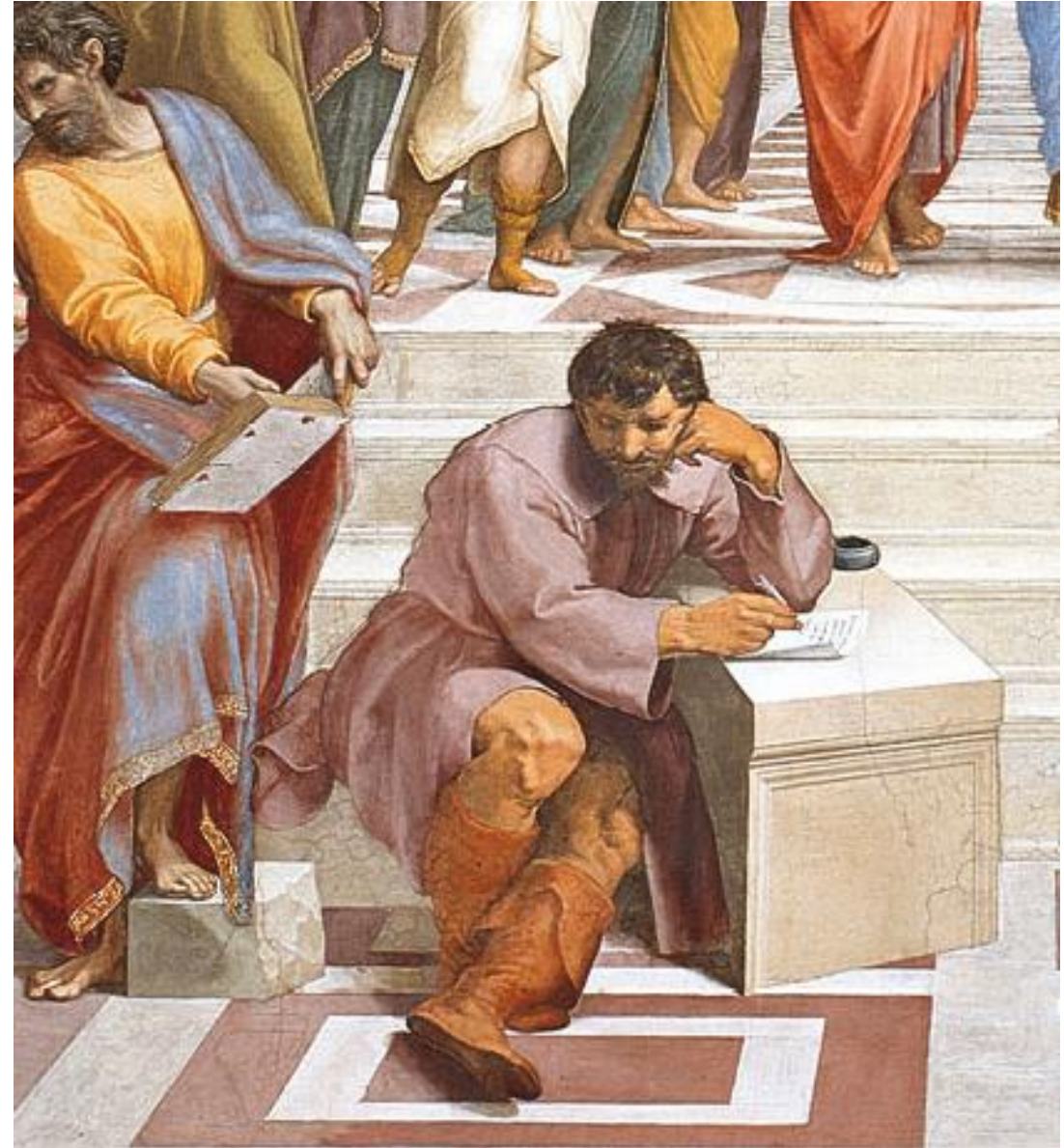

La Roma di Giulio II e Leone X

Raffaello – Le stanze Vaticane

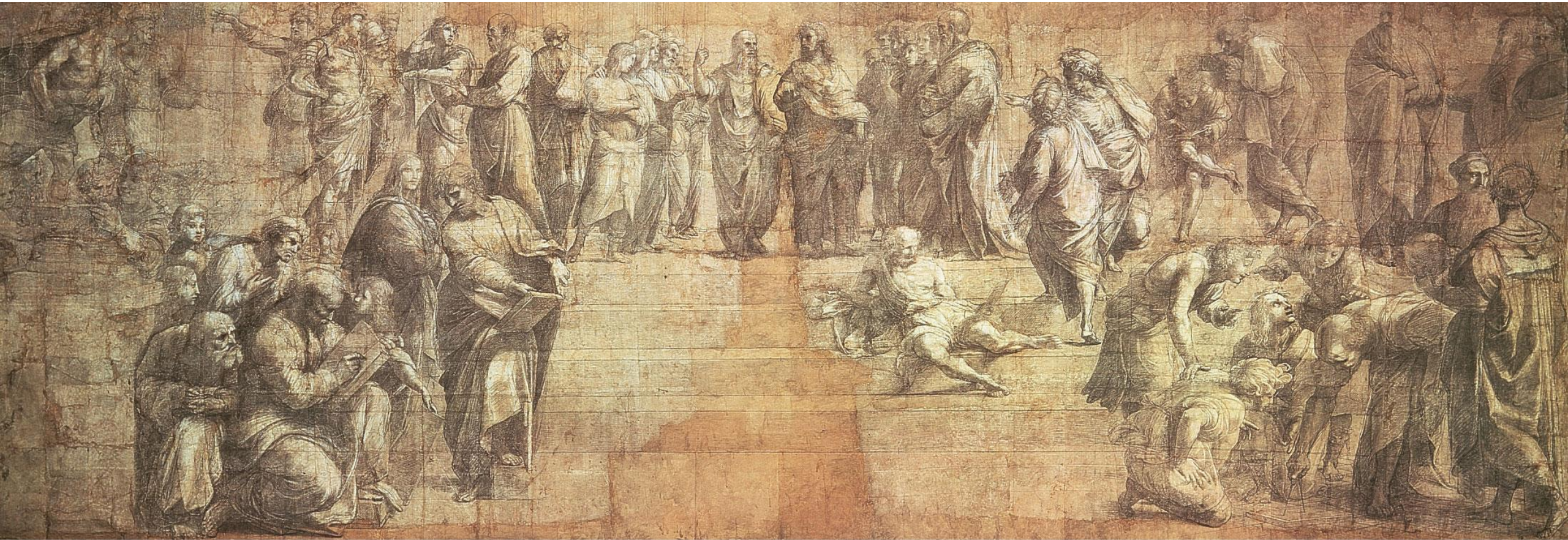

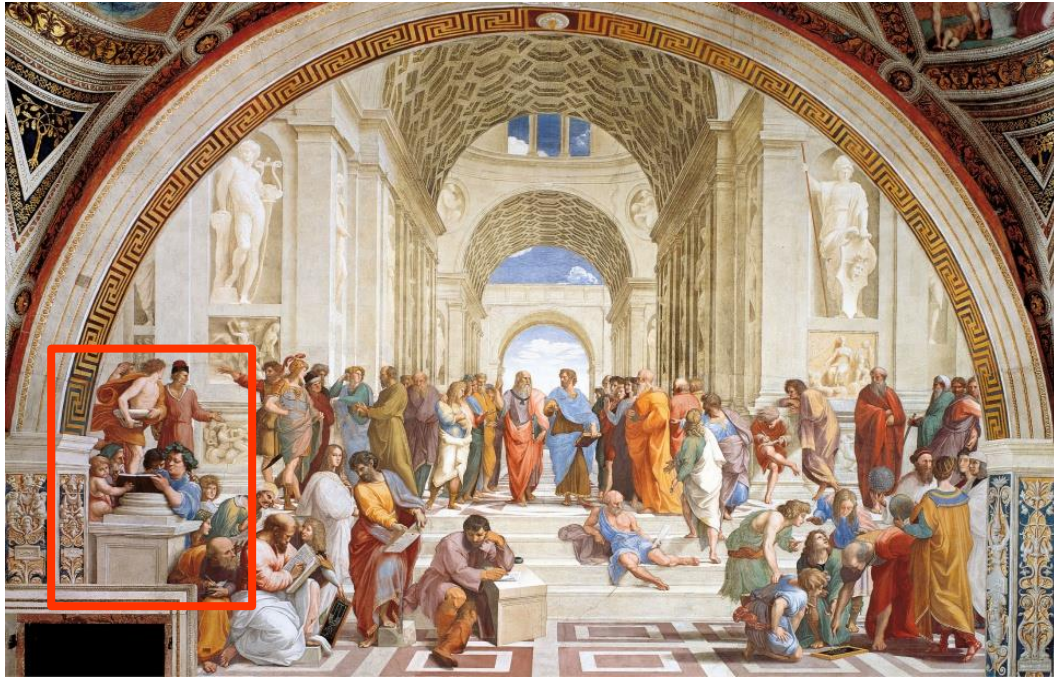

Epicuro

- A fianco si notano un giovane e un vecchio: secondo Platone l'educazione dei giovani iniziava con i miti raccontati dagli anziani.
- Sullo sfondo i Sofisti: **Protagora** con in mano le sue opere (due in forma di libro e una di rotolo)



La Roma di Giulio II e Leone X



Raffaello – Le stanze Vaticane

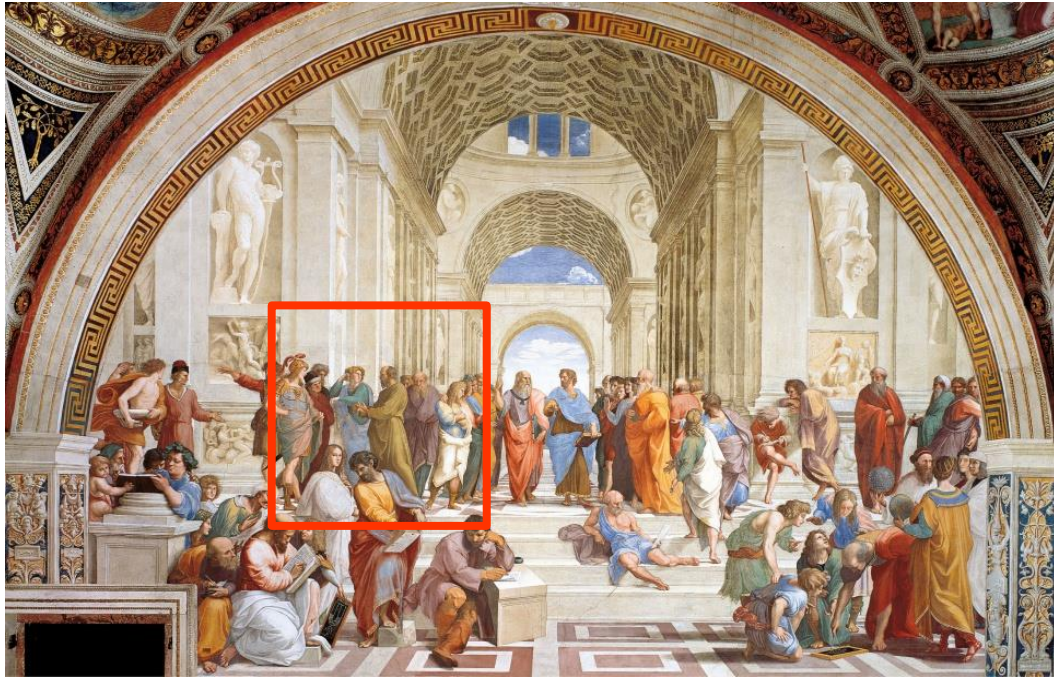

Socrate

Con l'aiuto delle dita argomenta un sillogismo al cospetto dei suoi allievi



La Roma di Giulio II e Leone X



Raffaello – Le stanze Vaticane

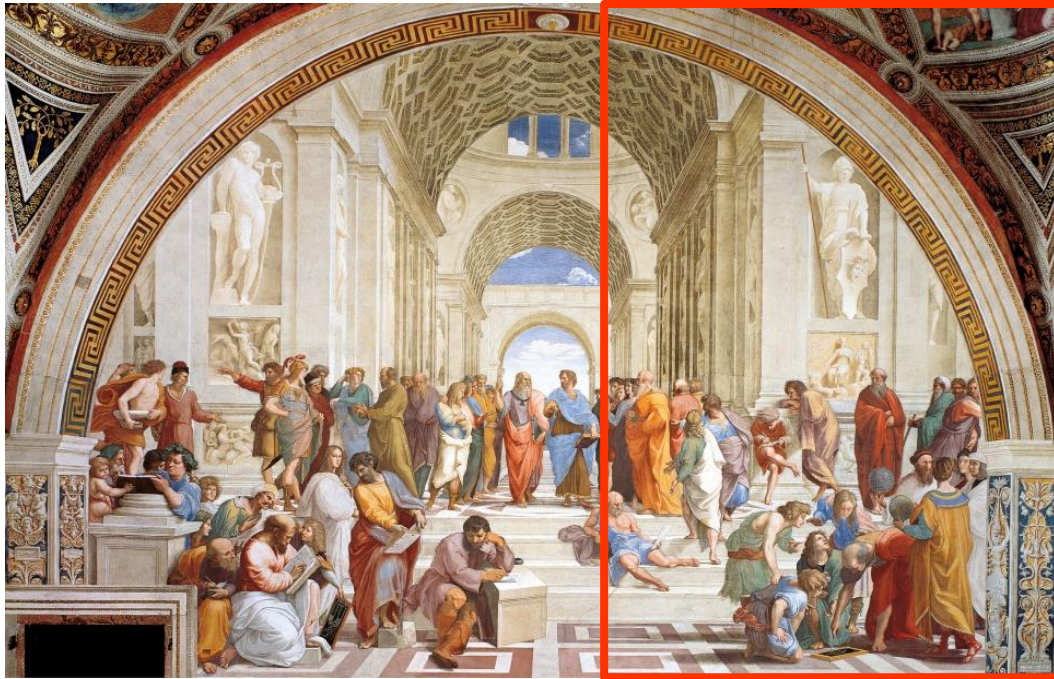

La metà destra

- In primo piano i geometri e gli astronomi, mentre in secondo piano ma in posizione più elevata i filosofi



La Roma di Giulio II e Leone X



Raffaello – Le stanze Vaticane



Minerva

Sovrana della Scienza e della Ragione

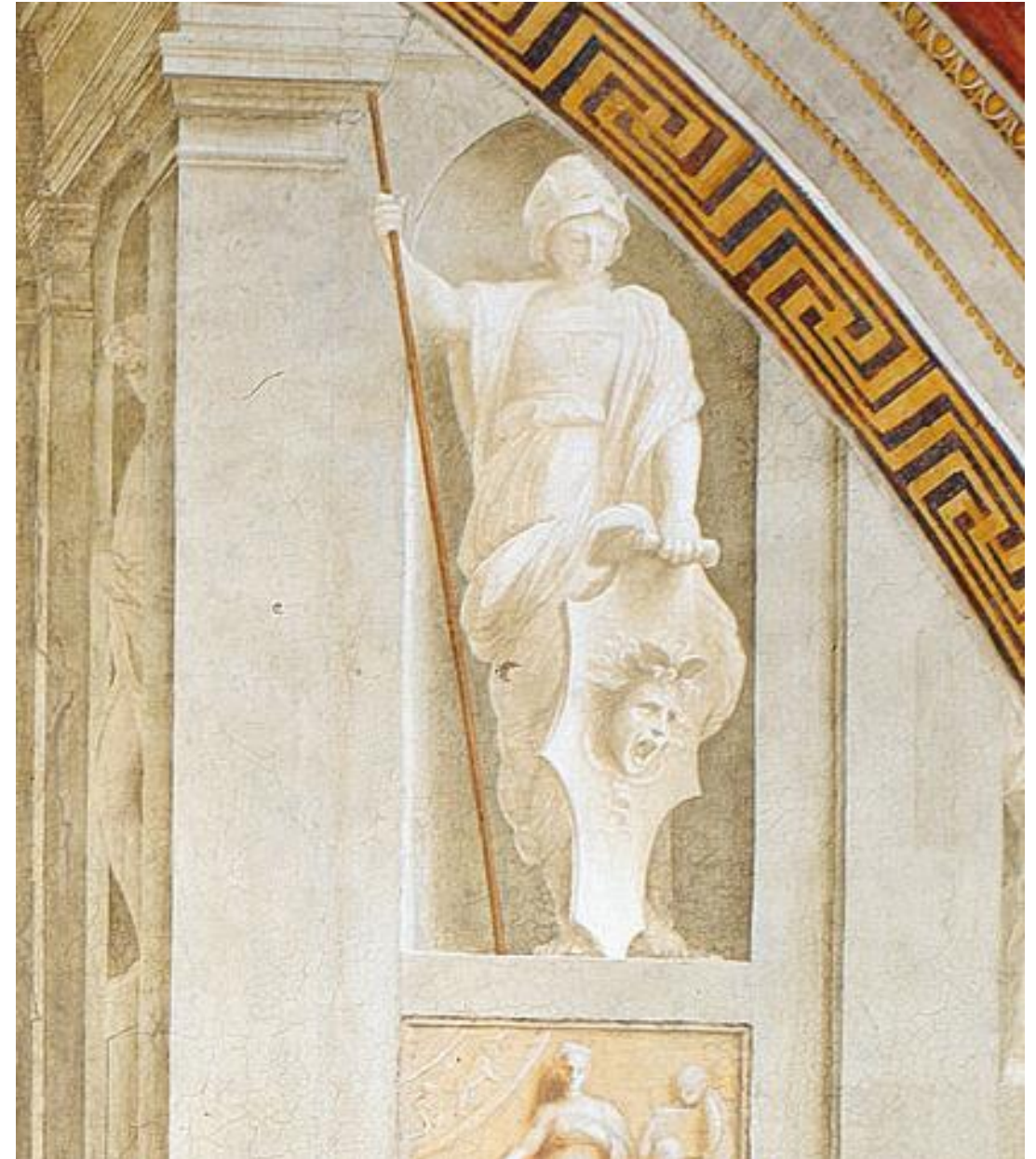

La Roma di Giulio II e Leone X



Raffaello – Le stanze Vaticane



Euclide

- Padre della geometria nell'atto di spiegare un teorema ad un capannello di allievi
- Ritratto di Donato Bramante





Zoroastro e Tolomeo

- **Zoroastro** fondatore dell'astronomia;
- Davanti a lui **Tolomeo** che codificò il sistema geocentrico: è raffigurato con il globo in mano

Raffaello



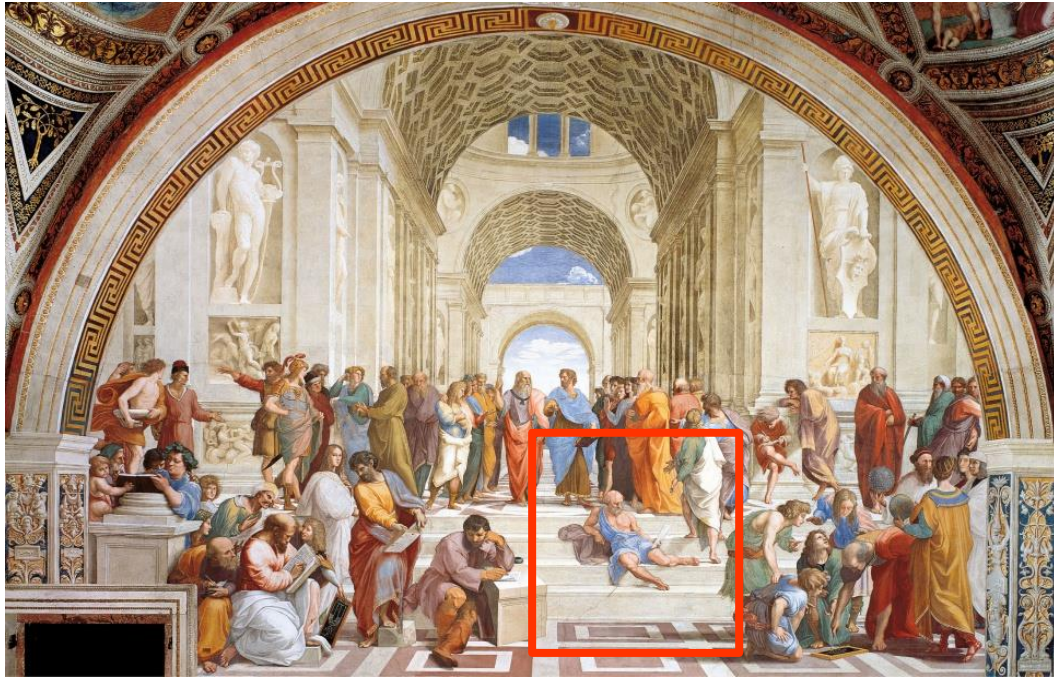

Diogene

- Abbigliamento essenziale e con il dettaglio della ciotola: una volta vide un fanciullo che beveva nel cavo della mano, così gettò via la sua ciotola dicendo: un fanciullo mi ha dato una lezione di semplicità;
- Esprime l'atteggiamento tipico del filosofo di età ellenistica che tendeva a ridurre all'essenziale i bisogni umani



La Roma di Giulio II e Leone X

Raffaello – Le stanze Vaticane



La Roma di Giulio II e Leone X

Michelangelo – Volta della Cappella Sistina







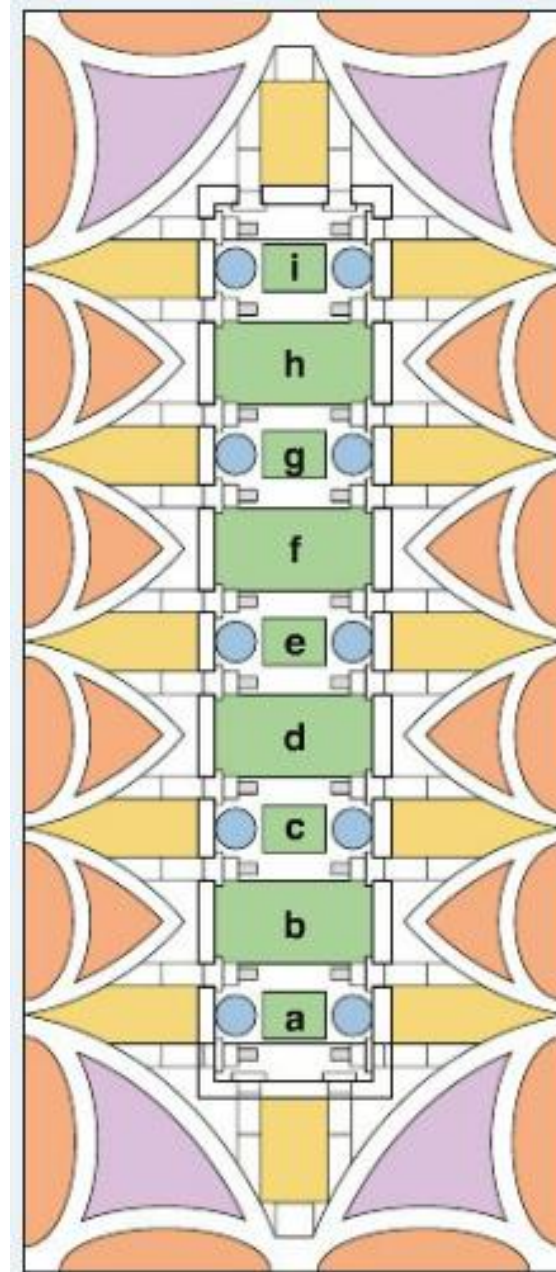

La Roma di Giulio II e Leone X

Michelangelo – Volta della Cappella Sistina



Veduta generale e schema dei soggetti

-  *Antenati di Cristo*
-  *Sibille e Profeti*
-  *Eventi miracolosi a favore del popolo ebraico*
-  *Ignudi*
-  *Medaglioni in finto bronzo*
-  *Storie della Genesi:*
 - a.** *Separazione della luce dalle tenebre*
 - b.** *Creazione delle piante e degli astri*
 - c.** *Separazione della terra dalle acque*
 - d.** *Creazione di Adamo*
 - e.** *Creazione di Eva*
 - f.** *Peccato originale e cacciata dal paradiso terrestre*
 - g.** *Sacrificio di Noè*
 - h.** *Diluvio universale*
 - i.** *Ebbrezza e derisione di Noè*



Separazione della terra dalle acque

Creazione degli astri e delle piante

Separazione della luce dalle tenebre



Peccato originale

Creazione di Eva

Creazione di Adamo

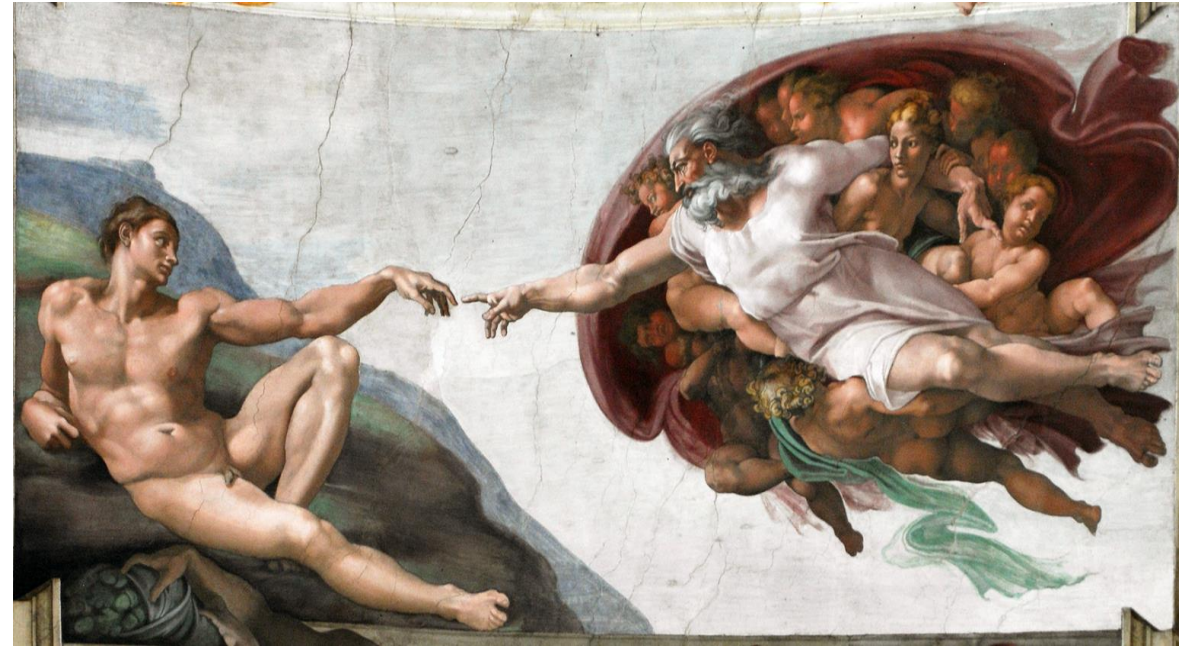

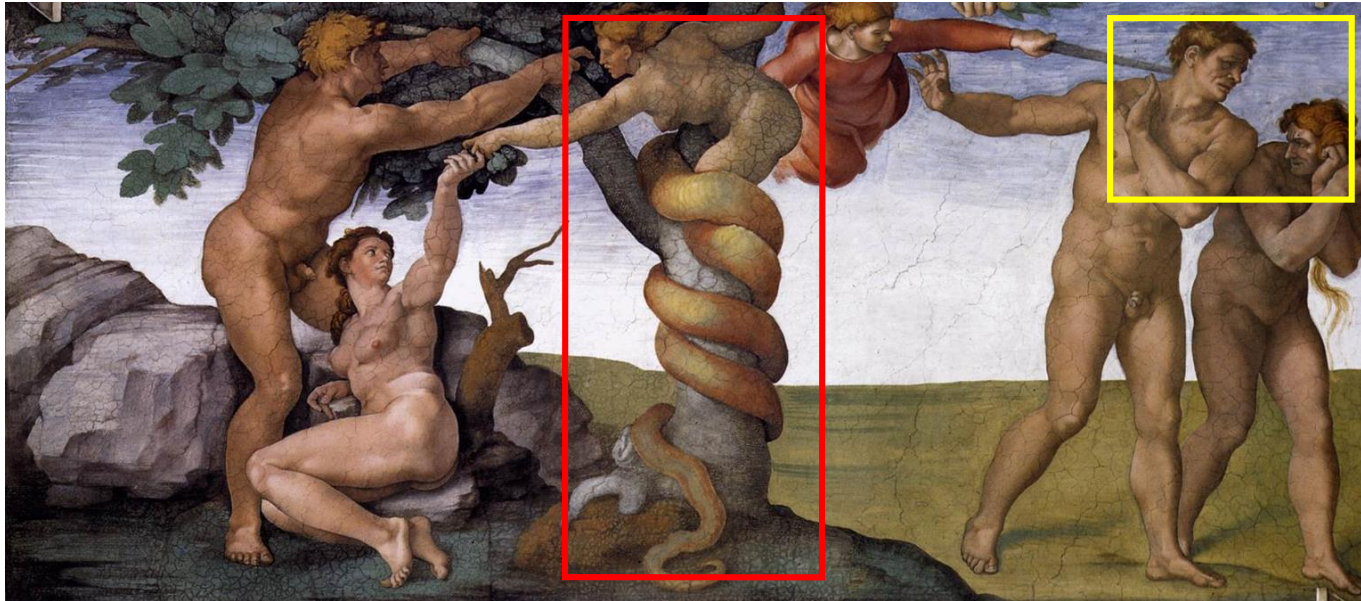



Ebbrezza di Noè

Diluvio Universale

Sacrificio di Noè

Giuditta e
Oloferne



David e Golia

Serpente di
bronzo



Punizione di Aman

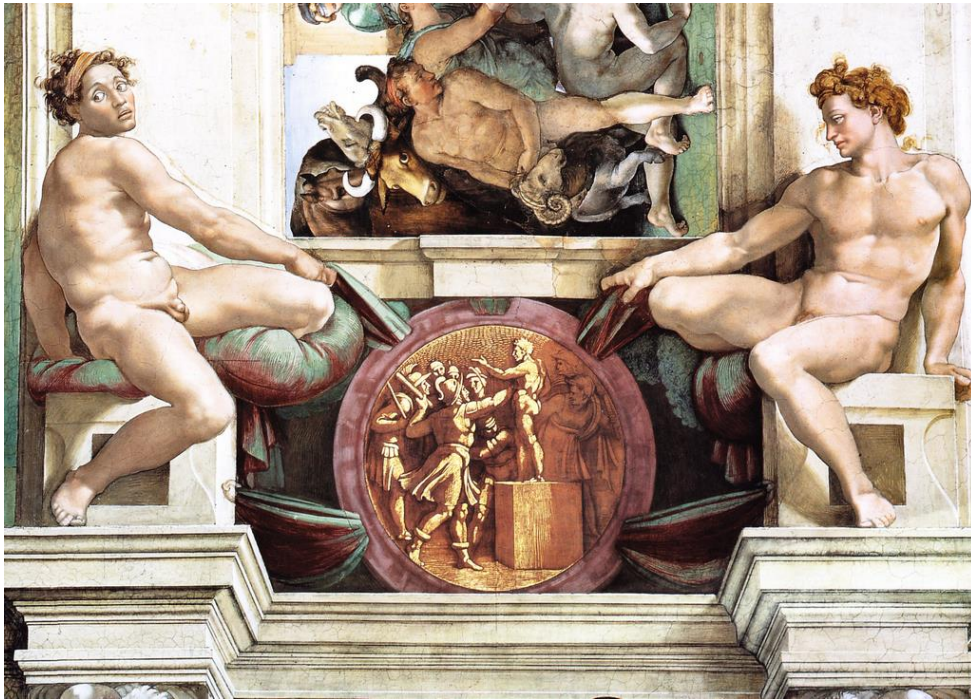

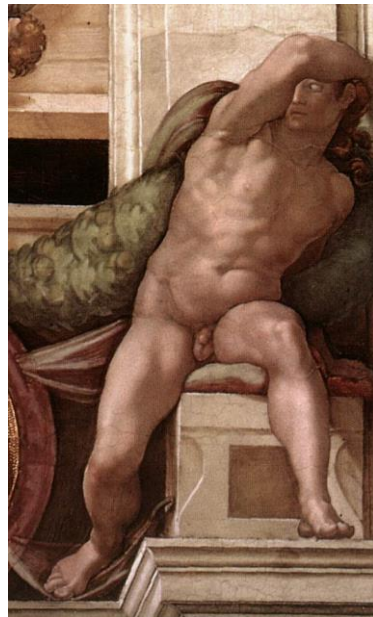
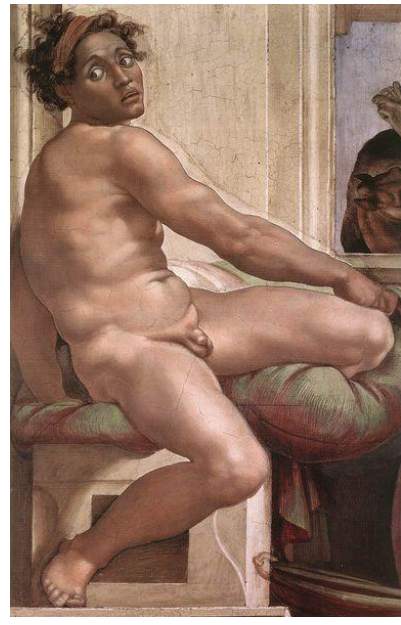
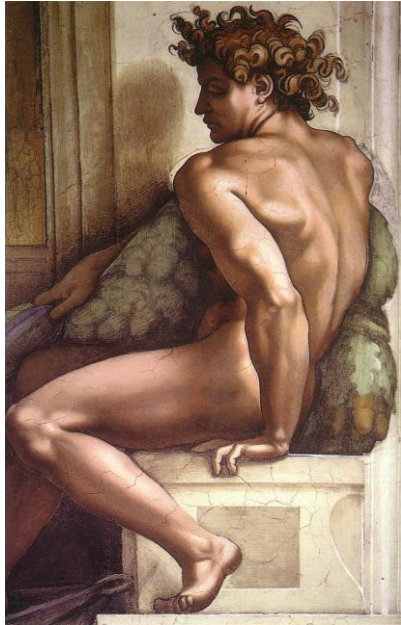
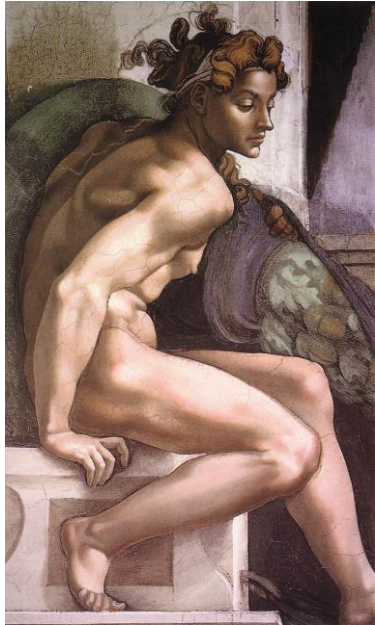

La Roma di Giulio II e Leone X

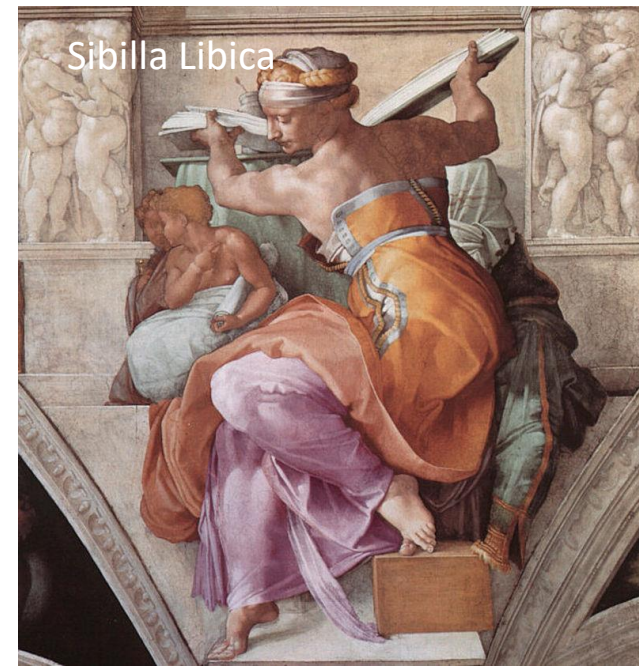
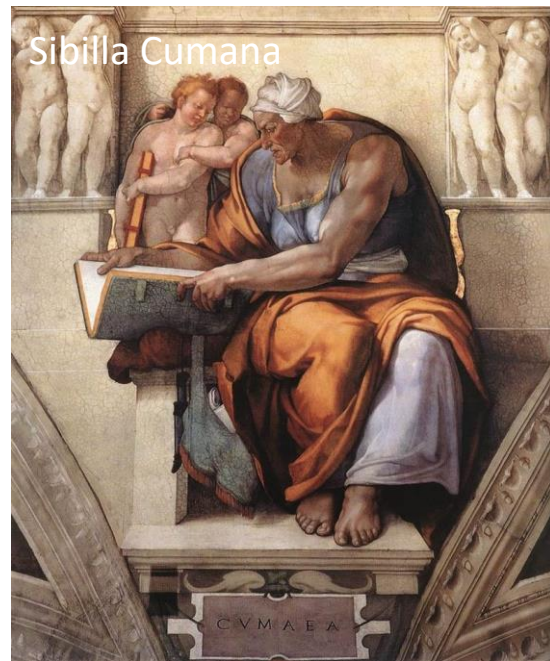
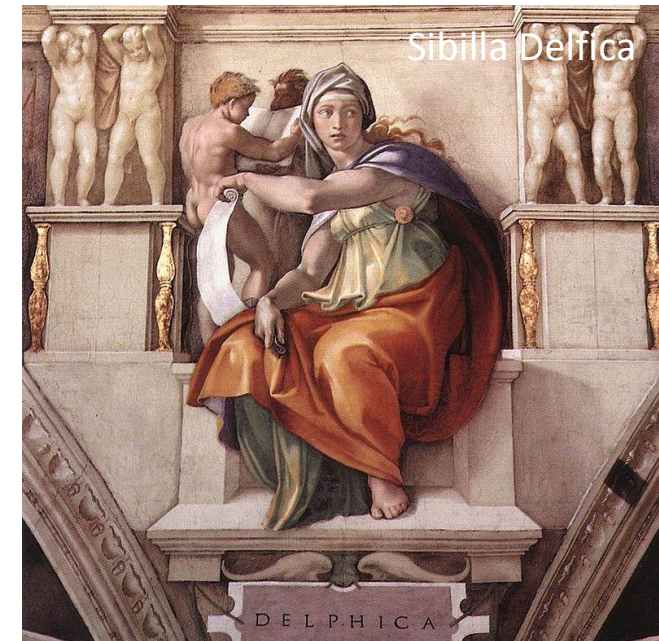
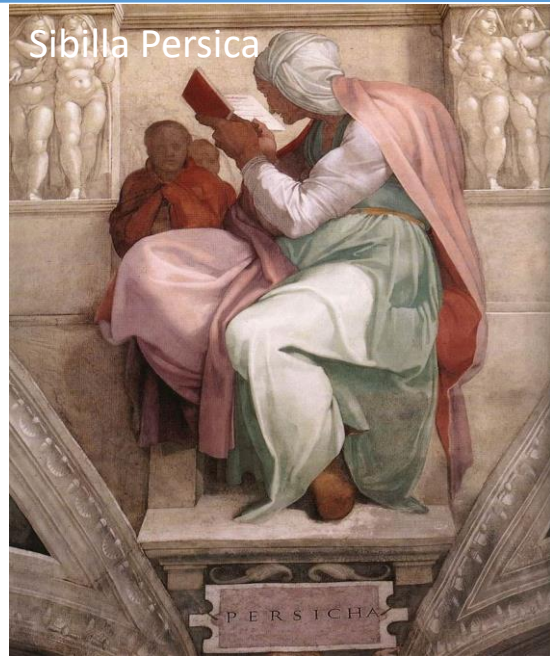

La Roma di Giulio II e Leone X

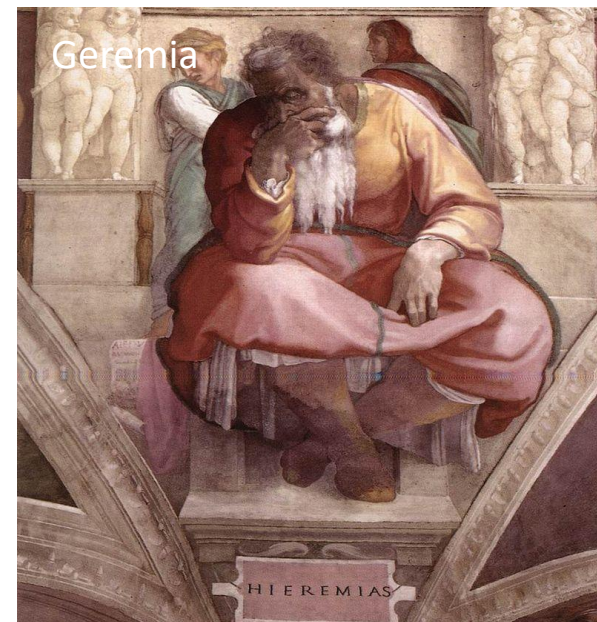
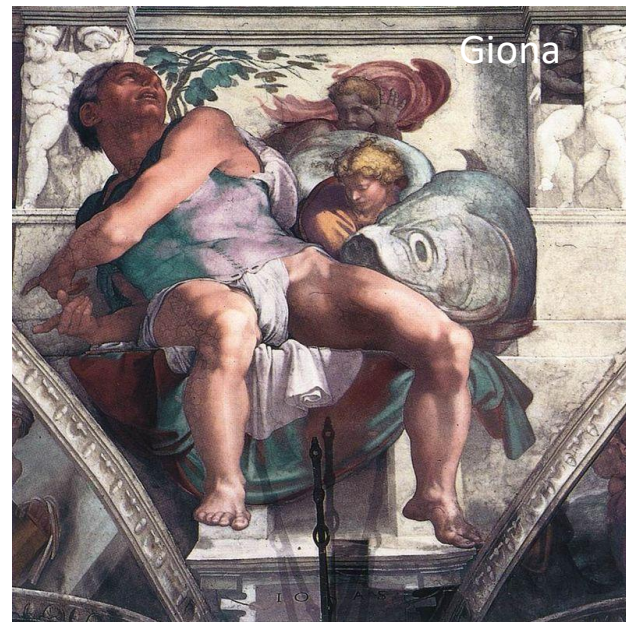
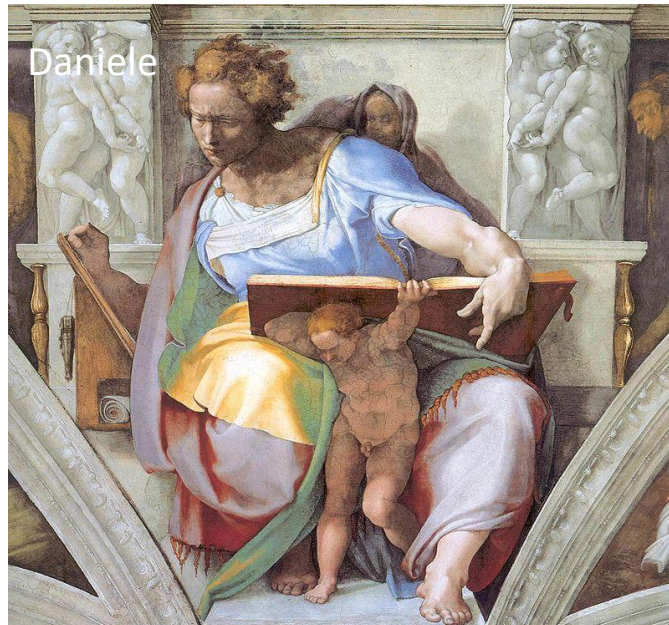
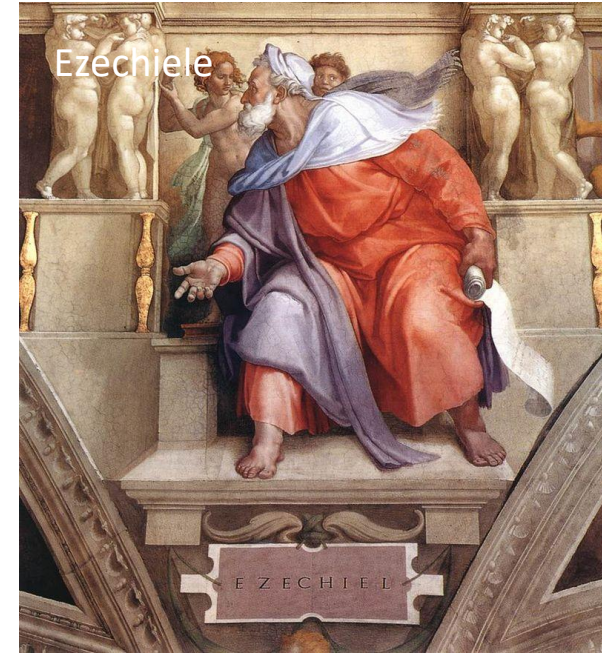
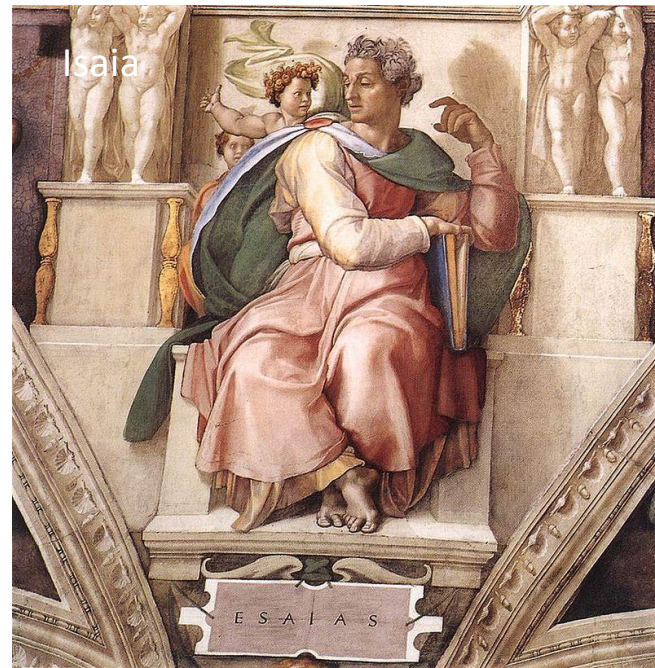



Zaccaria

La Roma di Giulio II e Leone X

Michelangelo – Tomba di Giulio II

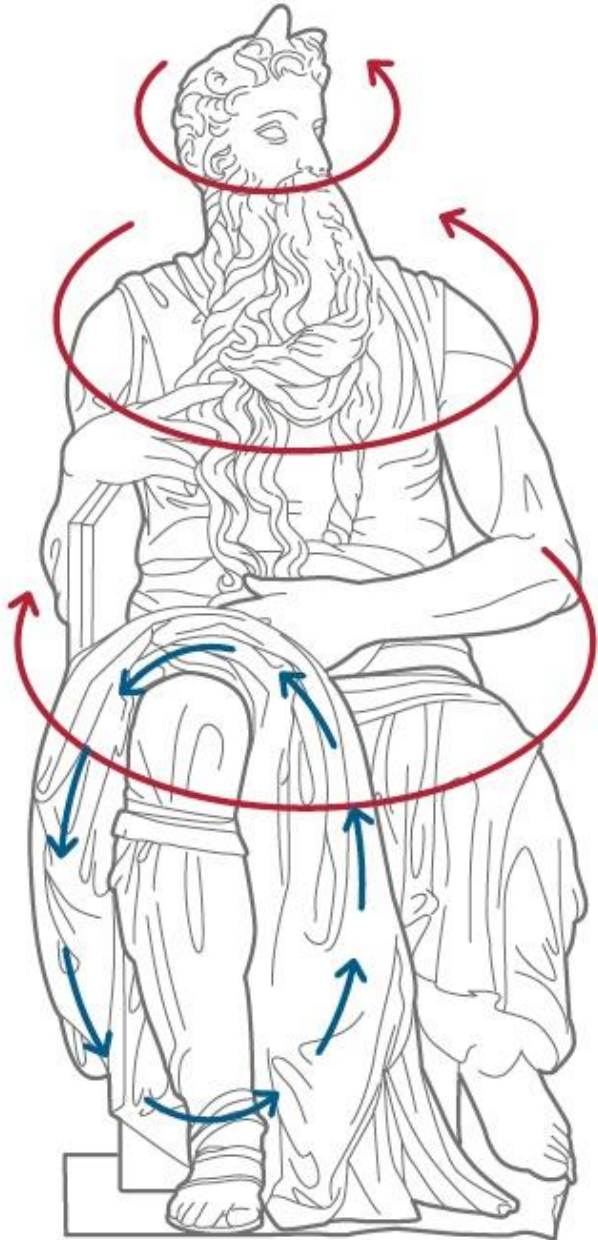

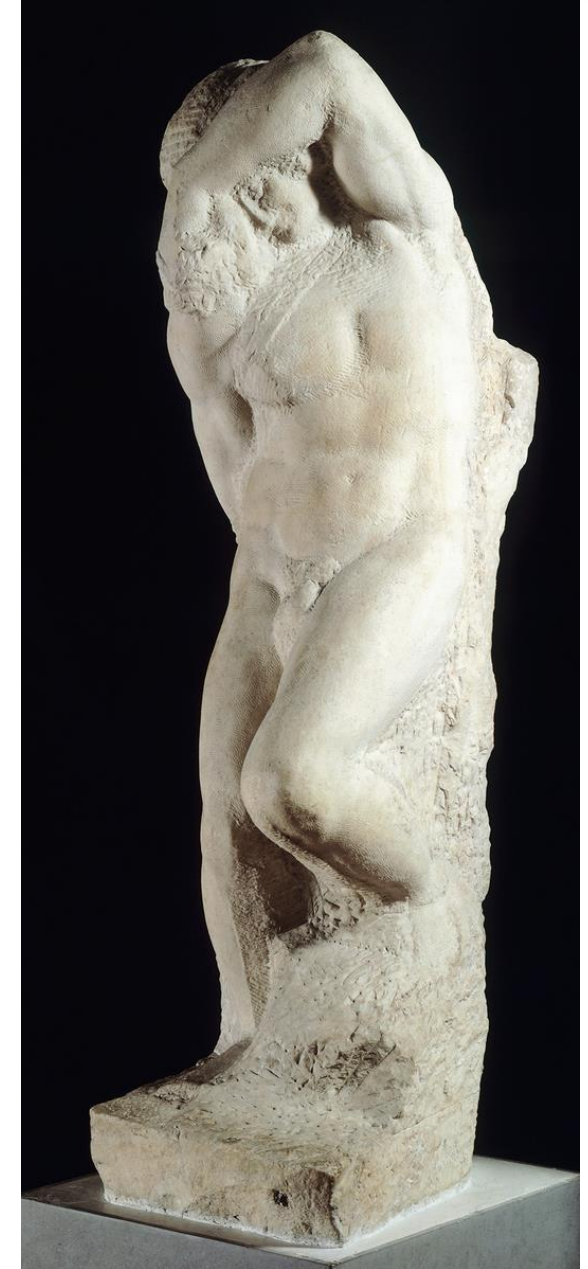
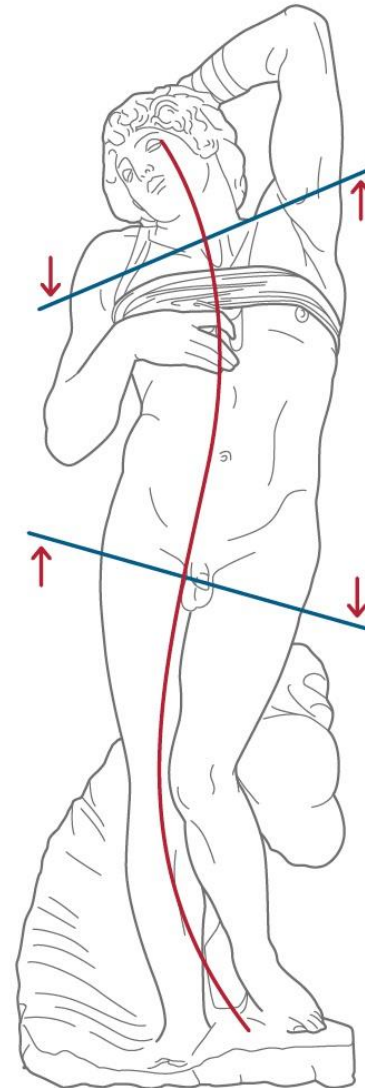



Stanza di Eliodoro

- 6. Liberazione di San Pietro dal carcere
- 7. Cacciata di Eliodoro dal tempio
- 8. Messa di Bolsena
- 9. Incontro di Leone Magno e Attila

La Roma di Giulio II e Leone X



Raffaello – Le stanze Vaticane – La stanza di Eliodoro



ANN. D. M. D. X. III.

La Roma di Giulio II e Leone X

Raffaello – Le stanze Vaticane – La stanza di Eliodoro



La Roma di Giulio II e Leone X



Raffaello – Le stanze Vaticane – La stanza di Eliodoro



La Roma di Giulio II e Leone X

Villa Chigi

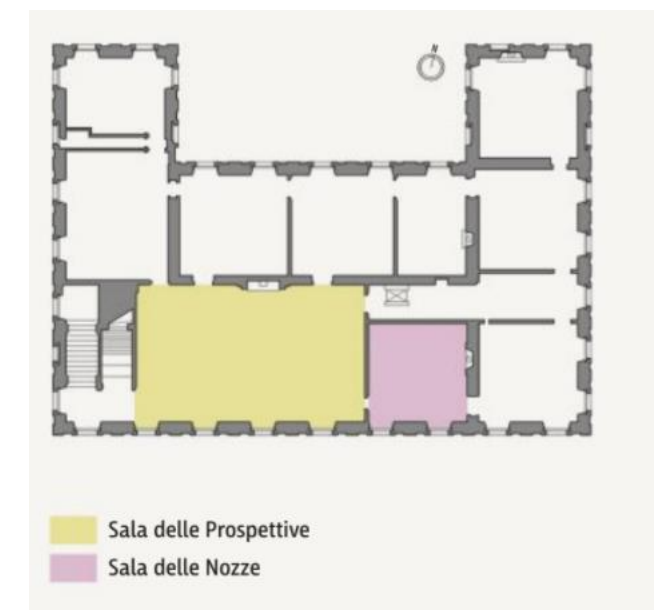

La Roma di Giulio II e Leone X

Villa Chigi



La Roma di Giulio II e Leone X

Villa Chigi

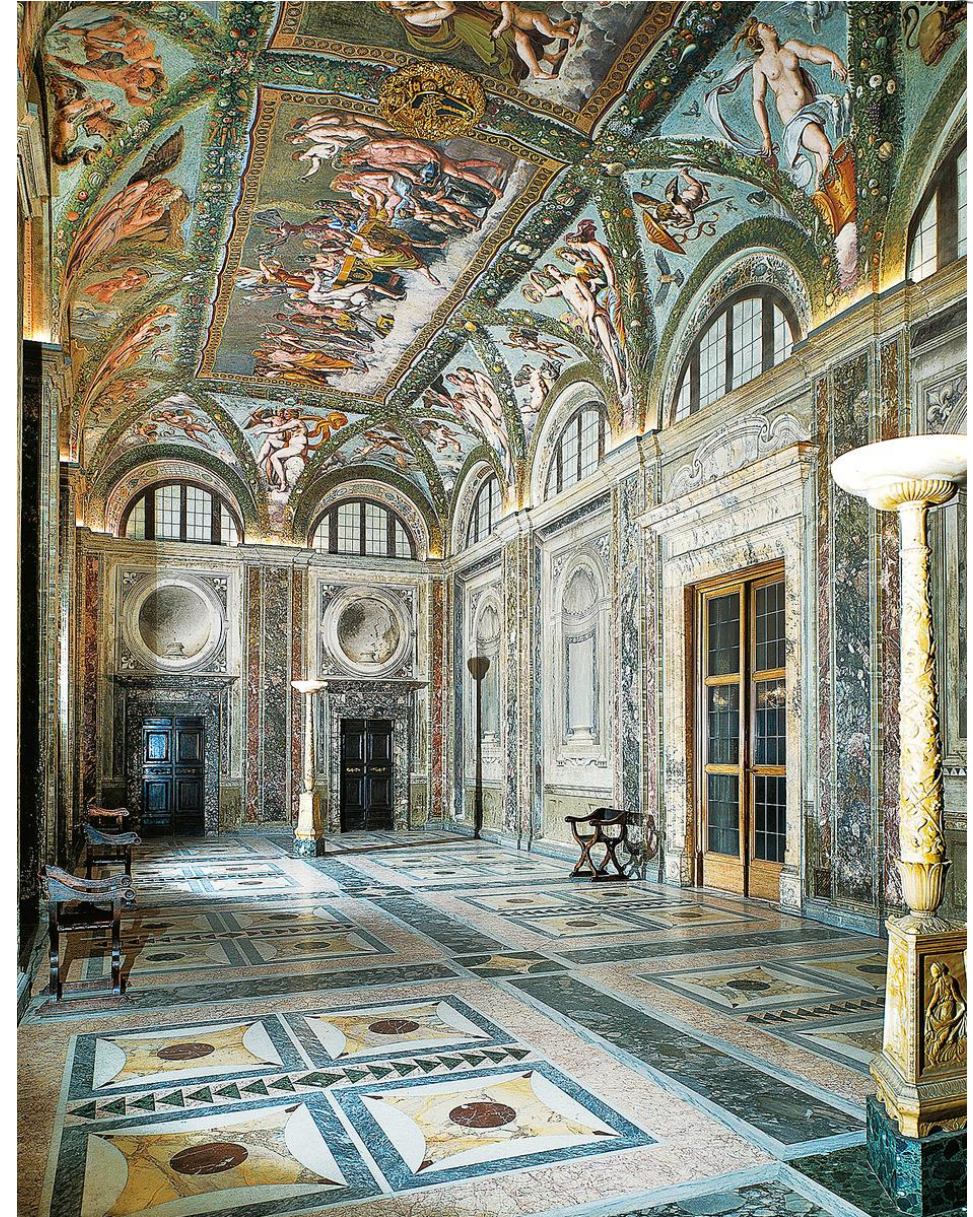

La Roma di Giulio II e Leone X

Villa Chigi



La Roma di Giulio II e Leone X

Raffaello – Le stanze Vaticane – L'incendio del borgo



La Roma di Giulio II e Leone X



Raffaello – Logge Vaticane

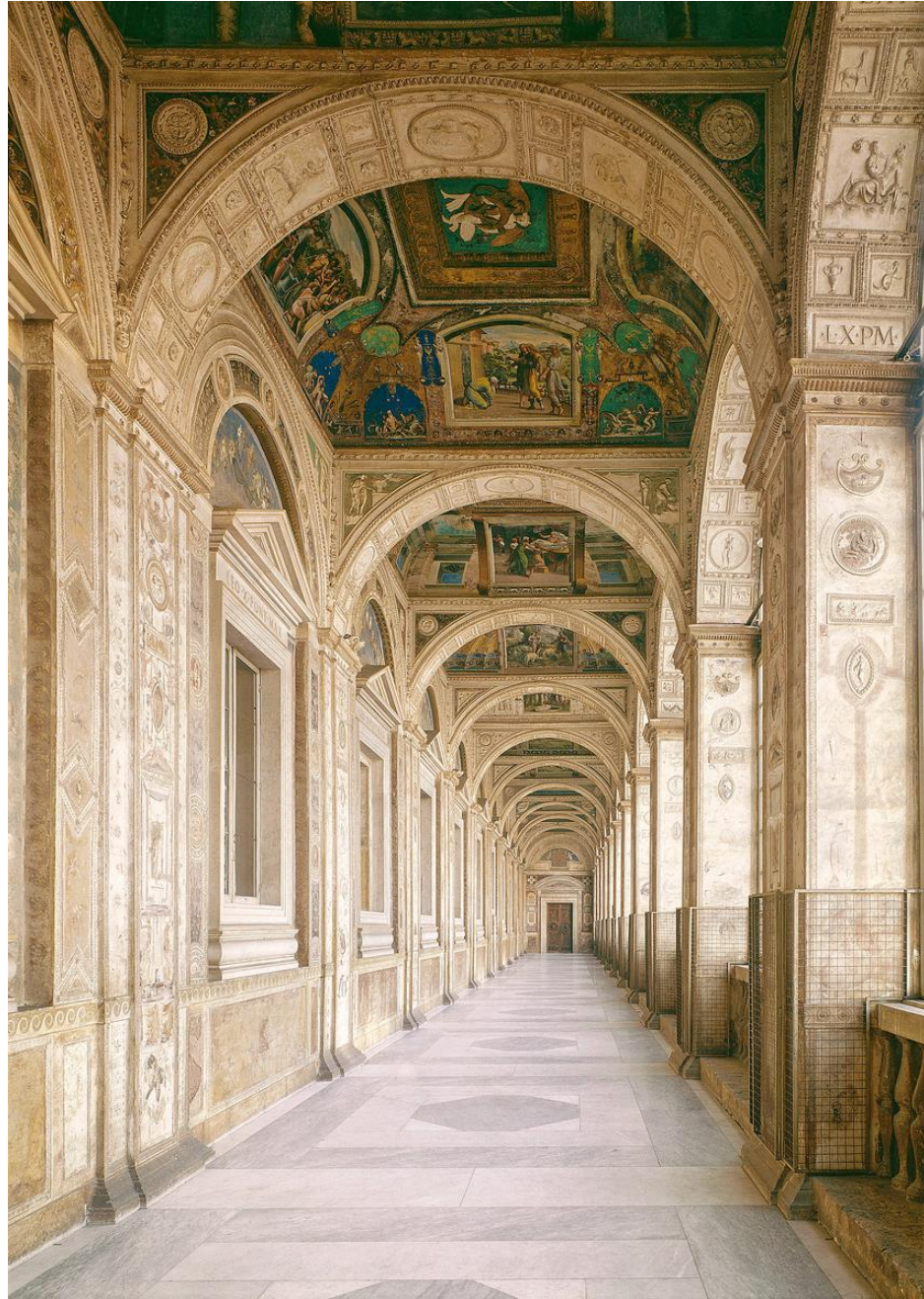

La Roma di Giulio II e Leone X

